

## Air to Water Heat Pump

### Split system

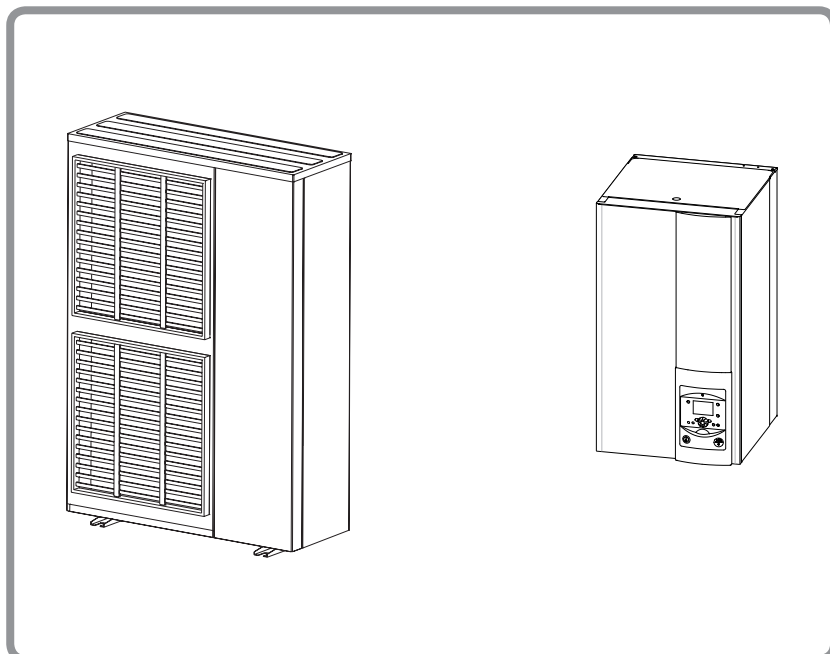
Outdoor unit  
WOYG112LHT  
WOYG112LCTA  
WOYG140LCTA  
WOYK112LCTA  
WOYK140LCTA  
WOYK160LCTA

Hydraulic unit  
WSYG140DG6  
WSYK160DG9



**Installation and  
operating manual**  
intended for professionals

To be saved for  
future consultation



☞ This device requires for its installation, the intervention of qualified personnel with a certificate of capacity for handling refrigerants.

## Contents

<b>Description of the unit . . . . .</b>		<b>4</b>
Package . . . . .	4	Description . . . . . 9
Definitions . . . . .	4	Operating principle . . . . . 10
Specifications . . . . .	5	
<b>Installation . . . . .</b>		<b>12</b>
Regulation installation and maintenance conditions	12	Installation of refrigerant connections . . . . . 13
Unpacking and reservations . . . . .	12	Installation of the outdoor unit . . . . . 14
Receipt . . . . .	12	Installation precautions . . . . . 14
Handling . . . . .	12	Outdoor unit positioning . . . . . 15
Containment of refrigerant circuits . . . . .	12	Condensate drain hose . . . . . 15
Accessories provided . . . . .	12	Installing the hydraulic unit . . . . . 16
		Installation precautions . . . . . 16
		Positioning the hydraulic unit . . . . . 16
<b>Refrigerant gas connection and filling the installation with gas . . . . .</b>		<b>17</b>
Rules and precautions . . . . .	17	Check and connecting . . . . . 20
Shaping the refrigerant pipes . . . . .	17	Filling the installation with gas . . . . . 22
Bending . . . . .	17	Seal test . . . . . 23
Creating the flarings . . . . .	17	Creating a vacuum . . . . . 23
Accessing the hydraulic unit's refrigerant connections . . . . .	18	Filling the installation with gas . . . . . 24
		Sealing test . . . . . 24
		Additional charge . . . . . 24
		Pump down operation (Refrigerant collecting operation) outdoor unit . . . . . 25
<b>Hydraulic connecting . . . . .</b>		<b>26</b>
Connecting to the Heating circuit . . . . .	26	Filling and purging the installation . . . . . 27
Rinsing out the installation . . . . .	26	Heating circulation pump speed settings . . . . . 28
Connecting . . . . .	26	
Volume of the heating system . . . . .	27	

<b>Electrical connections</b> . . . . .	<b>30</b>
General . . . . .	30
Characteristic of the electrical supply . . . . .	30
General remarks on electrical connections . . . . .	30
Overview of all the electrical connections . . . . .	31
Cable section and protection rating . . . . .	31
Electrical connections on the single phase outdoor unit side . . . . .	32
Electrical connections on the 3- phase outdoor unit side . . . . .	33
<b>Electrical connections on the hydraulic unit side</b> . . . . .	<b>34</b>
Outdoor sensor . . . . .	38
Room thermostat and/or room control unit . . . . .	38
Installing a room sensor . . . . .	38
Installing a room control unit . . . . .	38
Fan convectors or dynamic radiators area . . . . .	38
<b>Commissioning</b> . . . . .	<b>38</b>
Configuring room thermostat . . . . .	39
Configuring room control unit . . . . .	39
<b>Regulation system</b> . . . . .	<b>40</b>
User interface, Room control unit (option) and Room thermostat (option) . . . . .	40
Description of the display . . . . .	42
Temperature control . . . . .	42
Set to . . . . .	42
Parametering the setting . . . . .	44
General . . . . .	44
Setting parameters . . . . .	44
Recommended settings according to the heat emitters installation . . . . .	44
List of function lines (settings, diagnosis, status). . . . .	45
<b>Overall hydraulic layout</b> . . . . .	<b>60</b>
<b>Electrical wiring diagrams</b> . . . . .	<b>62</b>
<b>Troubleshooting</b> . . . . .	<b>66</b>
Faults displayed on the hydraulic unit . . . . .	66
Faults displayed on the single phase outdoor unit . . . . .	68
Faults displayed on the 3-phase outdoor unit . . . . .	69
Information display . . . . .	70
<b>Maintenance of the installation</b> . . . . .	<b>71</b>
Hydraulic checks . . . . .	71
Checking the outdoor unit . . . . .	71
Electrical checks . . . . .	71
<b>Maintenance</b> . . . . .	<b>71</b>
Emptying the hydraulic unit . . . . .	71
Distribution valve . . . . .	71
<b>Quick-start procedure</b> . . . . .	<b>72</b>
Start-up check-list . . . . .	72
Before starting-up . . . . .	72
Starting-up . . . . .	73
Settings sheet . . . . .	74
Start-up data sheet . . . . .	75
<b>ErP performance values</b> . . . . .	<b>76</b>
<b>Instructions for the user</b> . . . . .	<b>77</b>

**Packing list**

<b>Heat Pump</b>	<b>Outdoor Unit</b>	<b>Hydraulic Unit</b>
<b>Model</b>	<b>Reference</b>	<b>Reference</b>
Waterstage High Power 11 single phase	WOYG112LHT	WSYG140DG6
	WOYG112LCTA	
Waterstage High Power 14 single phase	WOYG140LCTA	
Waterstage High Power 11 3-phase	WOYK112LCTA	WSYK160DG9
Waterstage High Power 14 3-phase	WOYK140LCTA	
Waterstage High Power 16 3-phase	WOYK160LCTA	

**Optional equipment**

- **2nd circuit kit** (code UTW-KZSXE) for connecting 2 heating circuits.
- **Regulation extension kit** (code UTW-KREXD) to manage a 2nd heating circuit, swimming pool, telephone modem etc...
- **DHW kit** (code UTW-KDWXD) for connecting a DHW tank (with built-in electrical back-ups).
- **Boiler connection kit** (code UTW-KBSXD) for connecting a boiler to the heat pump.
- **Room thermostat** (code UTW-C55XA), **Wireless room thermostat** (code UTW-C58XD) for correcting the ambient temperature.
- **Remote control** (code UTW-C74XF), **Wireless remote control** (code UTW-C78XA) for correcting the ambient temperature and programming the heat pump.
- **Cooling kit** (code UTW-KCLXD).
- **High flow rate circulating pump kit** (code UTW-PHFXD) for the installation of 1 circuit floor heating

**Scope of application**

This heat pump provides:

- Heating in winter.
- Control of two heating circuits\*.
- Production of domestic hot water\* (provided that combined with a DHW tank).
- Installation with boiler connection\* as a supplementary heating for the coldest days.
- Cooling in summer\* (for floor heating-cooling system or fan-convectors).
- Heating the swimming pool\*.

\* : These options require the use of additional kits (see chapter "Optional equipment").

# 1 Description of the unit

## 1.1 Package

- **1 package:** Outdoor unit.
- **1 package:** Hydraulic unit and outdoor sensor.

## 1.2 Definitions

- **Split:** The heat pump consists of two elements (an outdoor unit for outdoor and a hydraulic unit for inside the dwelling).
- **Air/water:** The surrounding air is the energy source. This energy is transmitted to the water in the heating circuit by the heat pump.
- **Inverter:** The fan and compressor speeds are modulated according to the heating requirements. This technology enables you to save on energy and operate on a single-phase power supply, whatever the heat pump's output, by avoiding heavy intensities on start-up.
- **COP** (coefficient of performance): This is the relationship between the energy transmitted to the heating circuit and consumed electrical energy.



### 1.3 Specifications

Designation model	Waterstage High Power	11 Single phase	14 Single phase	11 3-Phase	14 3-Phase	16 3-Phase
<b>Nominal heating performances</b> (outdoor temperature / initial temperature)						
<b>Heat output</b>						
+7 °C / +35 °C - Floor heating system	kW	10.80	13.50	10.80	13.50	15.17
-7 °C / +35 °C - Floor heating system	kW	10.80	12.00	10.80	13.00	13.50
+7 °C / +55 °C - Radiator	kW	7.59	9.68	9.29	10.60	12.71
-7 °C / +55 °C - Radiator	kW	7.57	9.20	9.27	10.10	12.00
<b>Power absorbed</b>						
+7 °C / +35 °C - Floor heating system	kW	2.55	3.24	2.52	3.12	3.72
-7 °C / +35 °C - Floor heating system	kW	4.32	5.08	4.28	5.13	5.40
+7 °C / +55 °C - Radiator	kW	3.07	3.95	3.52	4.40	4.93
-7 °C / +55 °C - Radiator	kW	4.57	5.08	5.09	5.65	6.89
<b>Coefficient of performance (COP)</b>	<b>(+7°C / + 35°C)</b>	<b>4.24</b>	<b>4.17</b>	<b>4.29</b>	<b>4.17</b>	<b>4.08</b>
<b>Electrical characteristics</b>						
Supply voltage (50 Hz)	V	230		400		
Maximum current for appliance	A	22	25	8.5	9.5	10.5
Nominal current	A	11.4	14.2	3.7	4.8	5.5
Maximum current of the electrical back-ups	A	26.1		13		
Power of the electrical back-ups	kW	ajustable 3 or 6 kW (single phase)		9 kW (3-phase)		
Real power absorbed by the circulation pump	W				39.5	
Maximum power absorption by the outdoor unit	W	5060	5750	5865	6555	7245
<b>Hydraulic circuit</b>						
Maximum operating pressure	MPa (bar)				0.3 (3)	
Hydraulic system flow rate (mini/maxi) 4°C< $\Delta$ t<8°C (nominal conditions)	l/h	1170 / 2340	1460 / 2920	1170 / 2340	1390 / 2790	1650 / 3290
<b>Various</b>						
Weight of outdoor unit	kg	92		99		
Sound power level according to EN 12102 <sup>1</sup> (hydraulic unit)	dB				46	
Sound power level according to EN 12102 <sup>1</sup> (outdoor unit)	dB	68	69	69	70	71
Weight of hydraulic unit (empty / full of water)	kg				42 / 58	
Water capacity of the hydraulic unit	l				16	
<b>Heating system operating limits</b>						
Hydraulic unit operation range	°C				0 / +45	
Outdoor temperature mini/maxi	°C				-25 / +35	
Initial max. heating water temperature Floor heating system	°C				45	
Initial max. heating water temperature Low temperature radiator	°C				60	
Flow min. heating water temperature	°C				8	
<b>Refrigeration circuit</b>						
Diameter of gas pipes	inches				5/8	
Diameter of liquid pipes	inches				3/8	
Factory charge of refrigerant R410A <sup>2</sup>	g				2500	
Maximum operating pressure	MPa (bar)				4.15 (41.5)	
Minimum / Maximum length of pipes <sup>3/6</sup>	m				5 / 15	
Maximum length of pipes <sup>4</sup> / Maximum level difference	m				20 / 15	

<sup>1</sup> The sound power level is a laboratory measure of the emitted sound power but contrary to the noise level, it doesn't correspond to the measure of the felt.

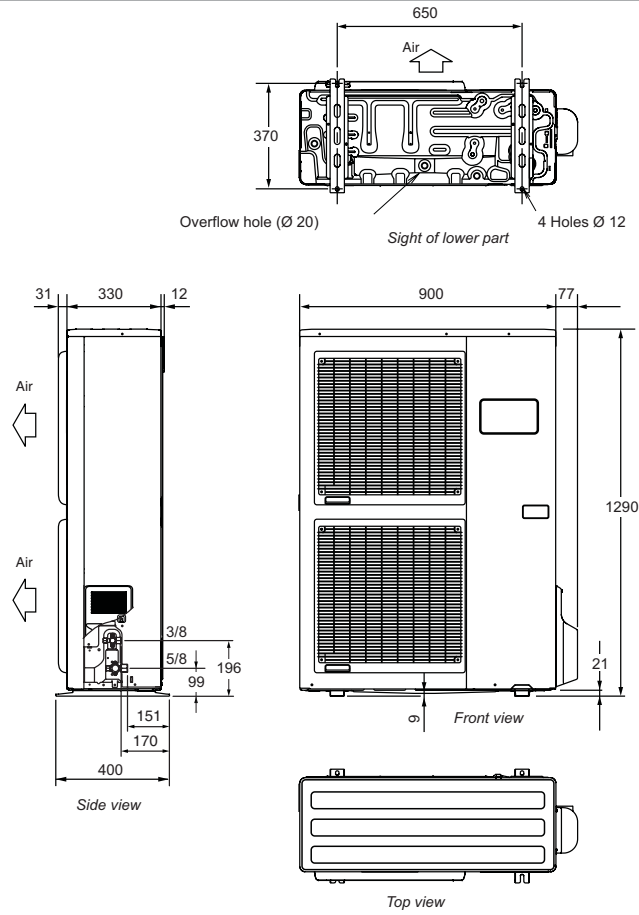
<sup>2</sup> Refrigerant R410A (as per the standard EN 378.1).

<sup>3</sup> Factory charge of refrigerant R410A.

<sup>4</sup> Taking into account the possible additional load of refrigerant R410A (see "Additional charge", page 24).

<sup>5</sup> The announced thermal and acoustic performances are measured with 7,5m length refrigerant lines.

**Outside unit,  
Model High Power  
11 & 14 single phase**



**Outside unit,  
Model High Power  
11, 14 & 16 3-phase**

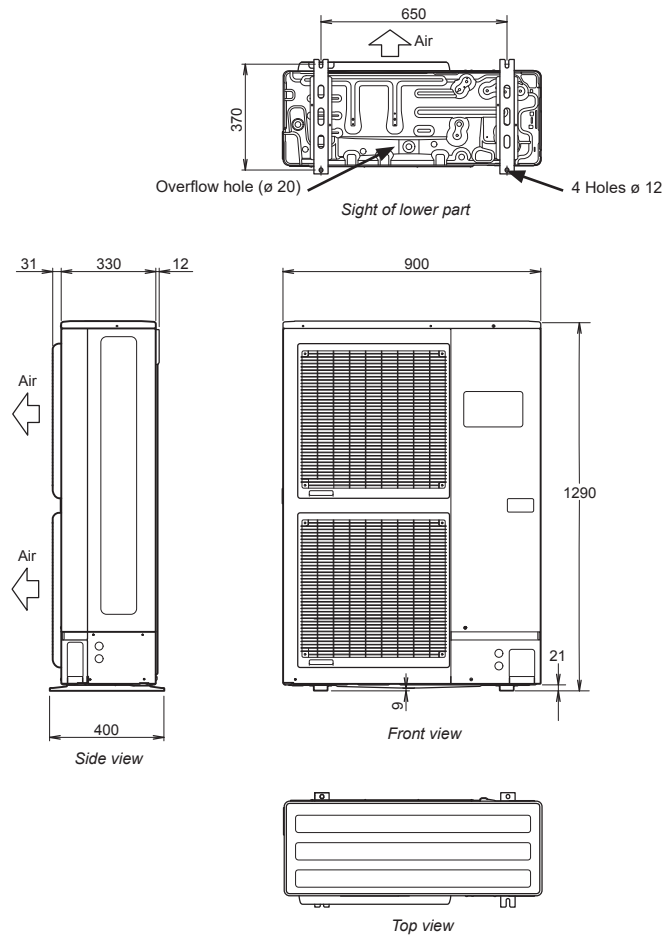
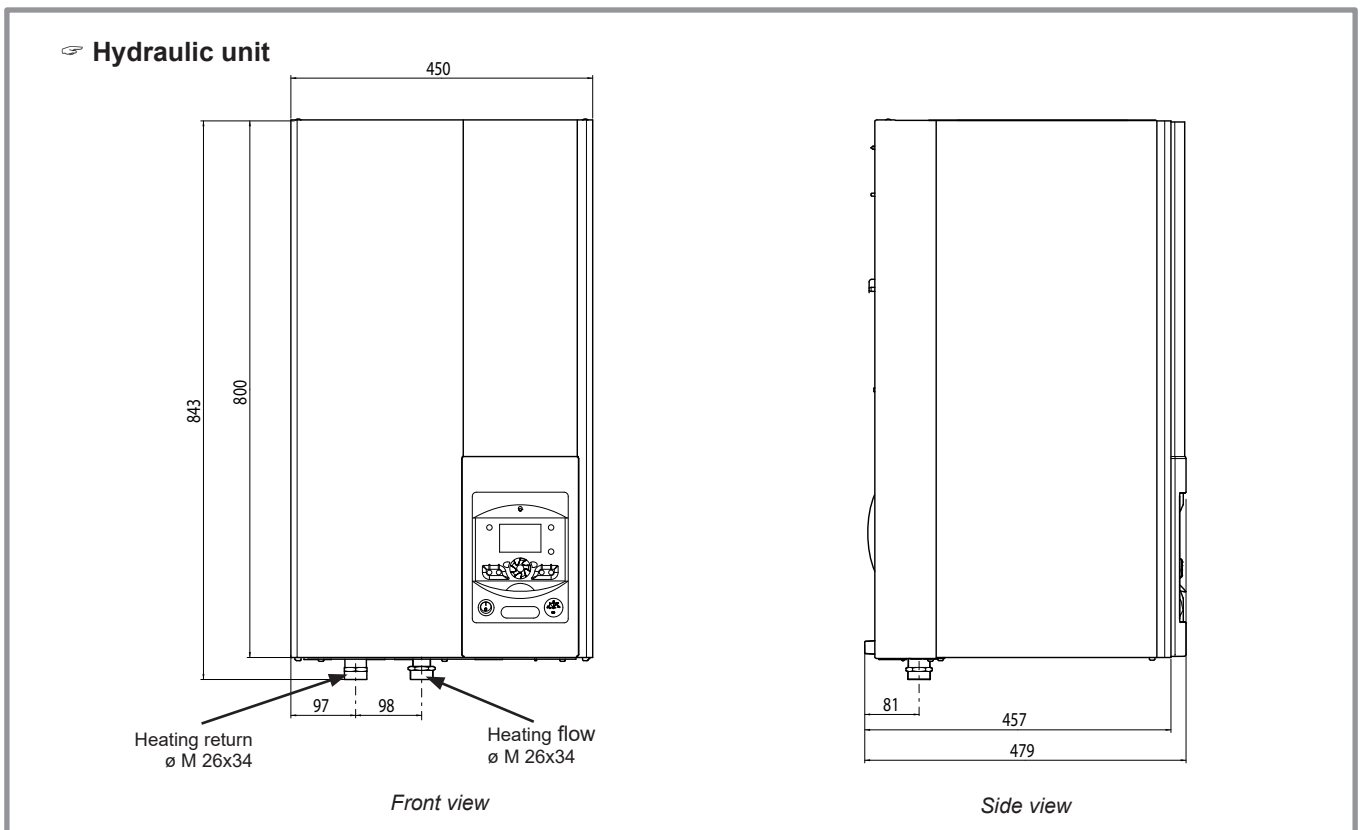


figure 2 - Dimensions in mm



**figure 3 - Dimensions in mm**

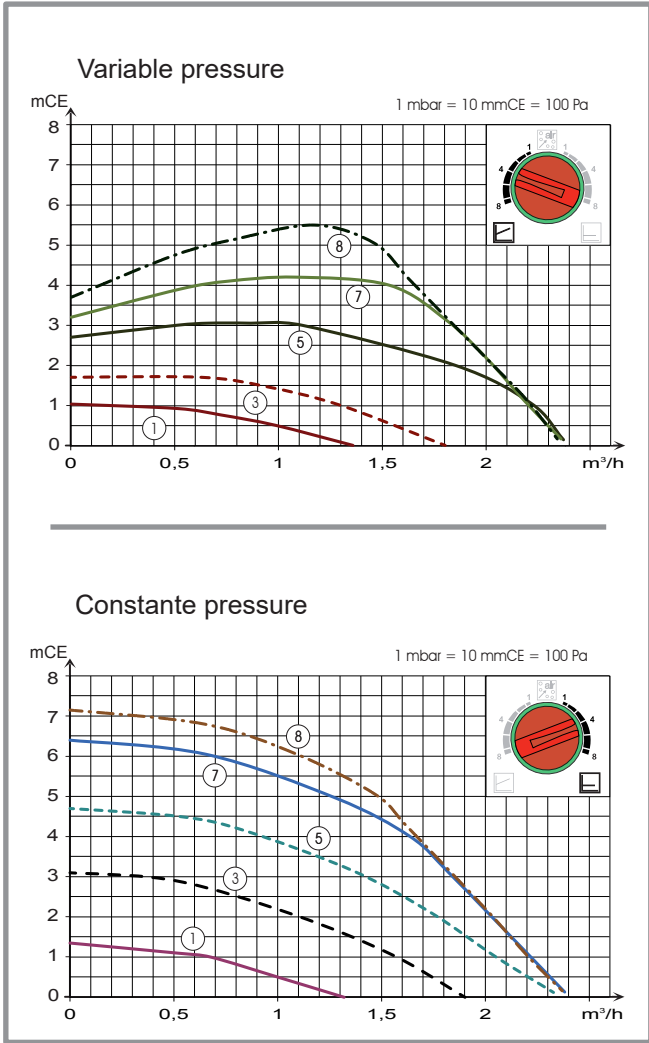


figure 4 - Hydraulic pressures and flow rates available

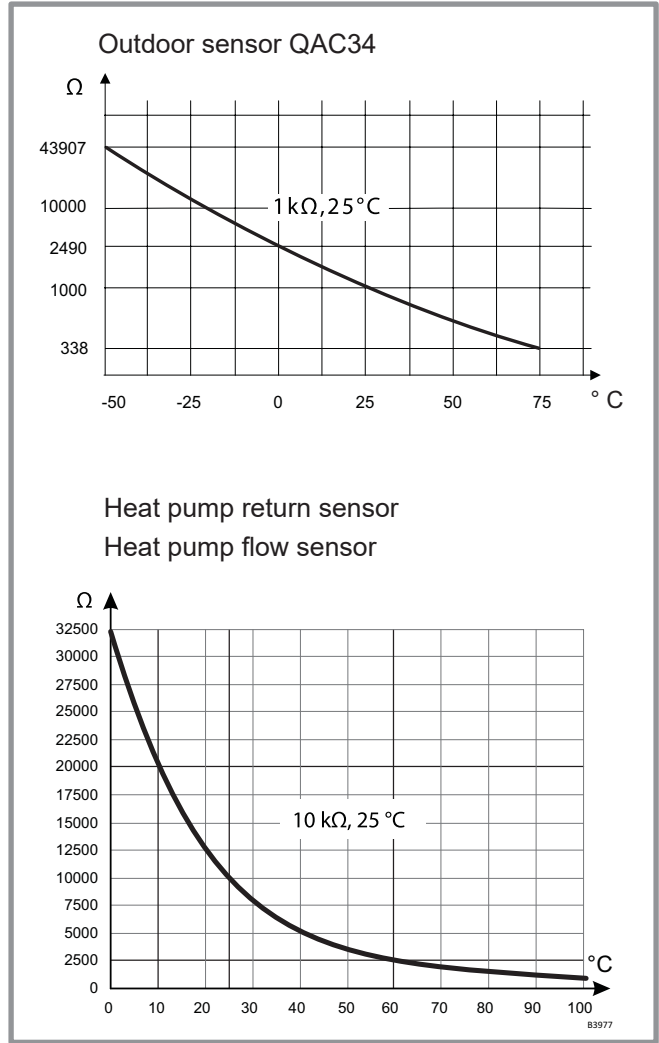


figure 5 - Ohmic values of the sensors (Hydraulic unit)

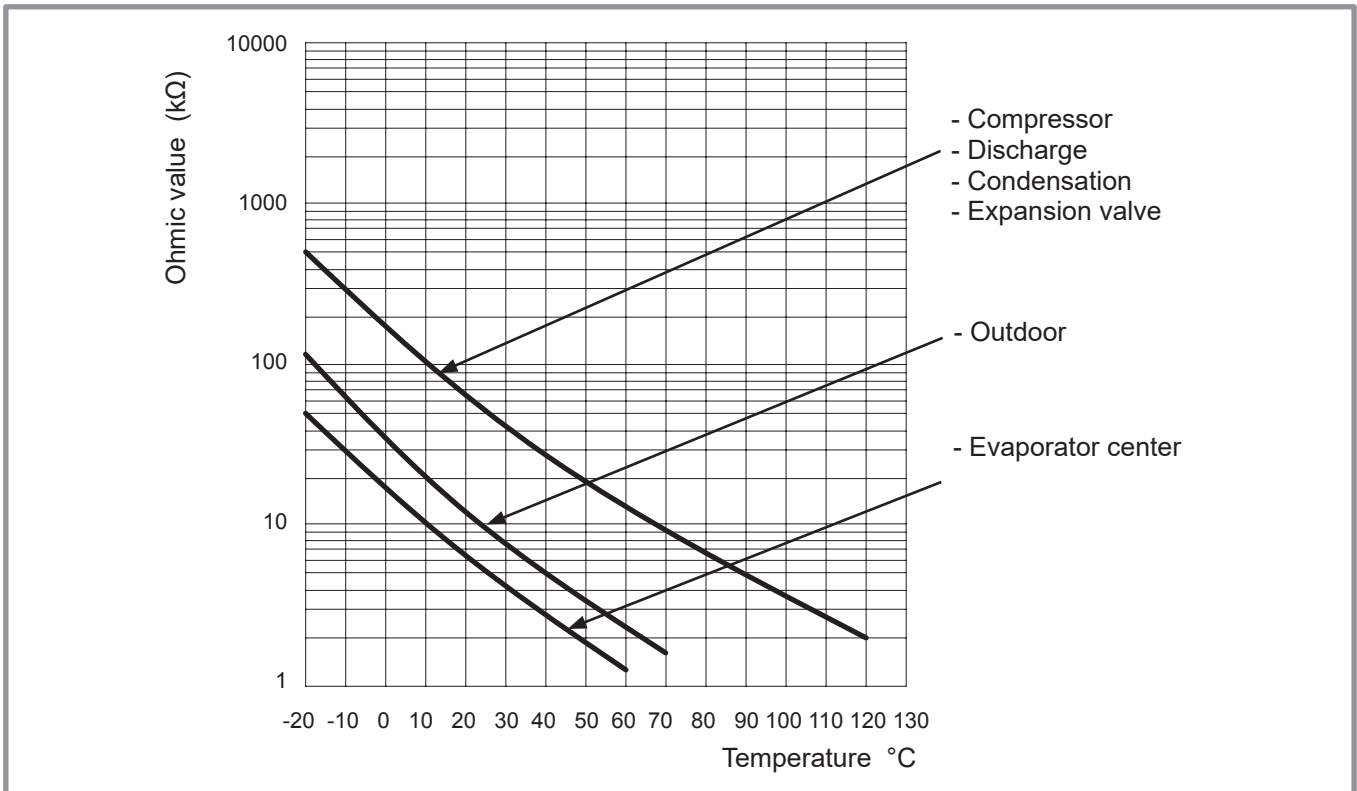


figure 6 - Ohmic values of the sensors (outdoor unit)

## 1.4 Description

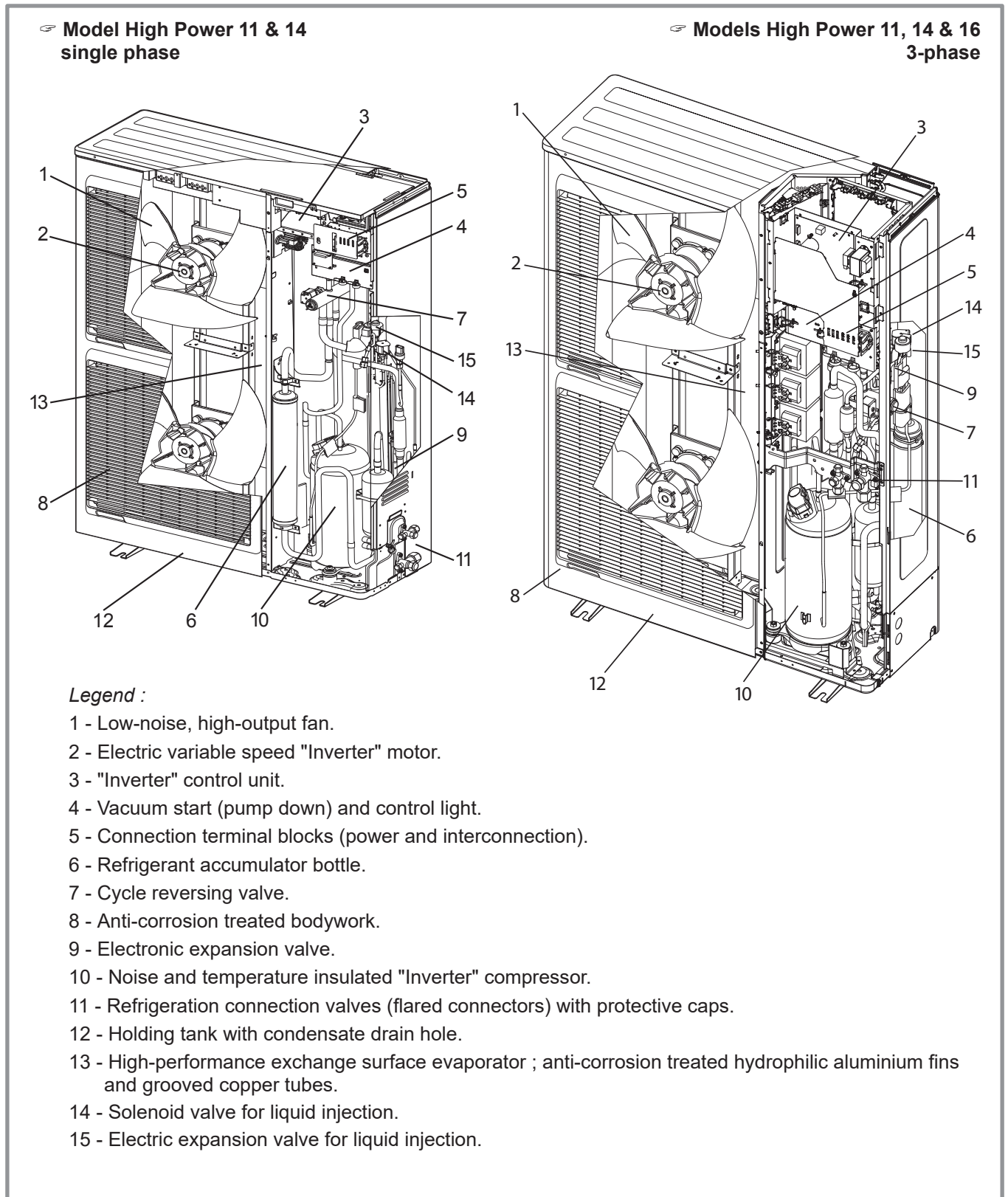


figure 7 - Outdoor unit components

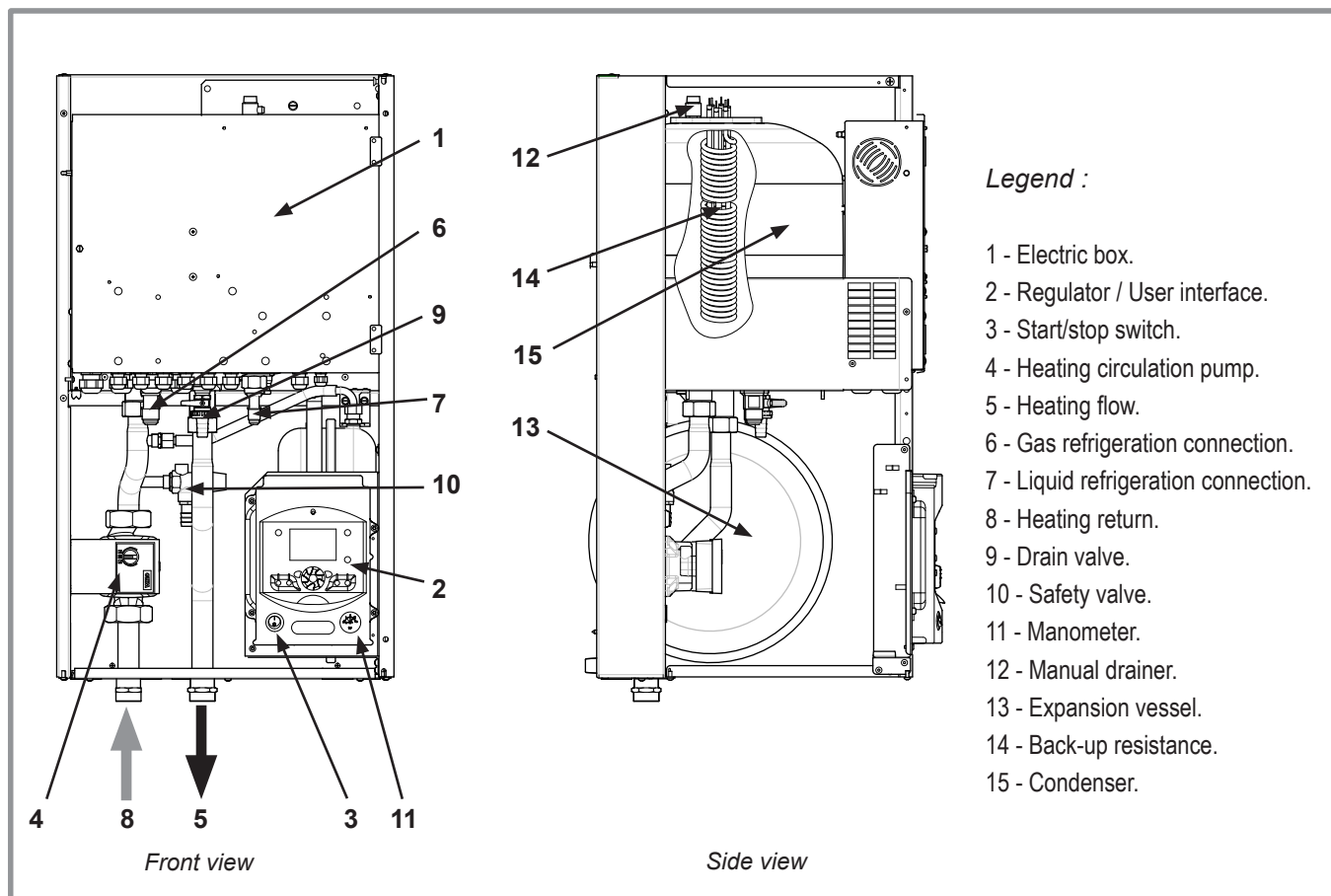


figure 8 - Hydraulic unit components

## 1.5 Operating principle

The heat pump transmits the energy contained in the surrounding air into the dwelling to be heated.

The heat pump consists of four main elements, in which a refrigerant fluid (R410A) circulates.

- In the evaporator (ref. **13**, figure 7, page 9) :  
The energy is taken from the surrounding air and is transmitted to the refrigerant. Because it has a low boiling point, it changes from the liquid state to the vapour state, even in cold weather (down to  $-25^{\circ}\text{C}$  outdoor temperature).
- In the compressor (ref. **10**, figure 7, page 9) :  
The vaporised refrigerant brought to high pressure and takes on more calories.
- In the condenser (ref. **14**, figure 8, page 10) :  
The energy in the refrigerant is transmitted to the heating circuit. The refrigerant returns to liquid state.
- In the expansion valve (ref. **9**, figure 7, page 9) :  
The liquefied refrigerant is brought back to low pressure and returns to its initial temperature and pressure.

The heat pump is equipped with a controller, which controls the room temperature based on the outdoor temperature measurement and governed by the temperature control. The room thermostat (option) provides a corrective action for the temperature control.

The hydraulic unit can be optionally fitted with an electrical back-up system or boiler connection which starts up in order to provide additional heating during the coldest periods.

### • Regulation functions

- The heating circuit's initial temperature is controlled by the temperature control.
- The power of the outdoor unit is modulated according to flow heating temperature via the "Inverter" compressor.
- Control of the electrical back-up heating
- The daily timer program enables you to define the periods for comfortable or reduced ambient temperature.
- Summer/winter mode switchover is automatic.
- Control of the supplementary boiler\* (options).
- The room thermostat (option)\*: provides a corrective action for the temperature control.
- Control of a second heating circuit\*.
- Domestic hot water\*: Heating time program, control of the operation of the DHW circulation pump.
- Managing the cooling\*.
- Control of swimming pool heating\*.

\* If the heat pump is equipped with optional equipment and the associated kits.

### • Protection functions

- Anti-legionella cycle for domestic hot water.
- Frost protection: Frost protection cuts in if the low-temperature point of the heating circuit falls below  $5^{\circ}\text{C}$ .

**• Domestic hot water (DHW) operating principle**

Two domestic hot water (DHW) temperatures can be parametered: nominal temperature (line 1610 to 55°C) and reduced temperature (line 1612 to 40°C).

The default heat pump program (line 560, 561 and 562) is set for nominal temperature from 0:00 to 5:00 and from 14:30 to 17:00 and for reduced temperature for the rest of the day. This optimizes electrical consumption while ensuring comfortable availability of hot water.

Setting for reduced temperature can be useful to prevent the DHW from switching on too often and for too long during the day.

The production of domestic hot water (DHW) is triggered when the temperature in the tank falls 7°C (setting from line 5024) below the set temperature.

The heat pump produces the domestic hot water, which is then additively heated, if required, by electrical back-up heating inside the tank. To ensure a DHW setting over 45°C, the electrical back-up heating or the boiler must be left on.

Depending on how the parameter (1620) is set, nominal temperature can be reached 24h/day or only at night or depending on the heat pump program.

If the contract concluded with the energy provider includes a subscription to day/night tariff, the electrical backup is subordinate to the supplier's power tariff and the comfort temperature may only be reached at night.

If no particular contract is concluded, the comfort temperature can be reached at any time, including during the day

The production of DHW takes priority over heating; nevertheless the production of DHW is controlled by cycles that control the times assigned to the heating and the production of DHW in the event of simultaneous demand.

A function to switch from "reduced" to "nominal" is provided on the front of the user interface. (see ref. 5, figure 39, page 40).

Anti-legionella cycles can be programmed.

**• Fan convectors with integrated control system**

Do not use a room sensor in the area.

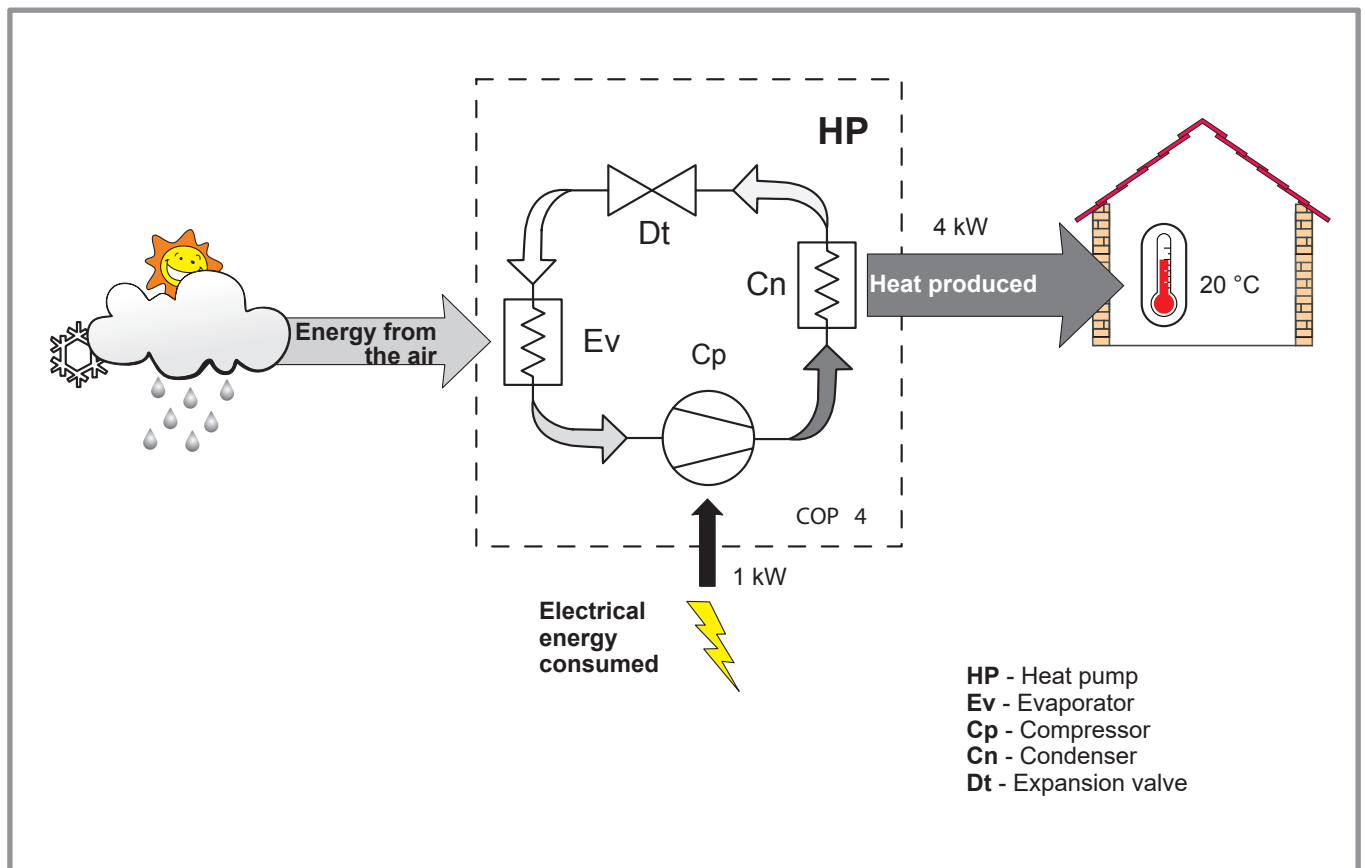


figure 9 - Heat pump operating principle



## 2 Installation

### 2.1 Regulation installation and maintenance conditions

The appliance must be installed and the maintained by an approved professional in accordance with the prevailing regulations and code of practice, in particular:

- The legislation on the handling of refrigerants.
- Heating installation with floor heating system.
- Low voltage electrical installations - Rules.

### 2.2 Unpacking and reservations

#### 2.2.1 Receipt

Carefully check, in the carrier's presence, the general appearance of the appliances and check that the outdoor unit is not laid on its side or back.

In the case of any dispute, state any appropriate reservations to the carrier in writing within 48 hours and send a copy of this letter to the After-Sales service.

#### 2.2.2 Handling

The outdoor unit should not be laid on its side or back during transport.

If not kept upright during transport, the appliance could be damaged through displacement of the refrigerant and deformation of the compressor suspension.

Any damage caused by transportation of the unit lying down is not covered by the warranty.

If necessary the outdoor unit may be tilted only during manual handling (to go through a door or use a staircase). This operation must be conducted very carefully and the appliance must be immediately restored to upright position.

### 2.2.3 Containment of refrigerant circuits

All refrigerant circuits fear contamination from dust and moisture. If such pollutants introduced into refrigeration circuit, they can contribute to degrade the reliability of the heat pump.

- ☞ **It's necessary to ensure correct containment connections and refrigerant circuits (hydraulic unit, outdoor unit).**
- ☞ **In case of subsequent failure and expertise, the finding of the presence of moisture or foreign objects into the compressor oil would lead to systematic exclusion of warranty.**

- Check upon receipt that the fittings and the refrigeration circuit caps mounted on hydraulic unit and outdoor unit are properly seated and locked (impossible to loosen bare hands). If this is not the case, tighten them using an against wrench.
- Check also that the refrigerant connections are sealed (plastic caps or tubes crushed at the ends and soldered). If the caps must be removed during installation (tubes cut by example), put back them as soon as possible.

### 2.2.4 Accessories provided

Accessories provided with the outdoor unit (figure 10).

Accessories provided with the hydraulic unit (figure 11).

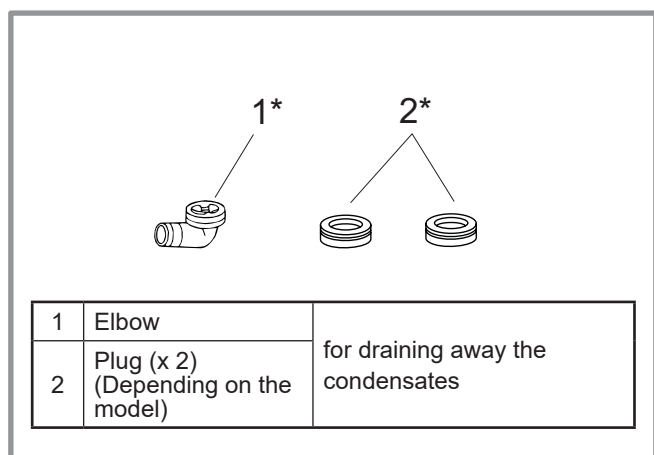


figure 10 - Accessories provided with the outdoor unit

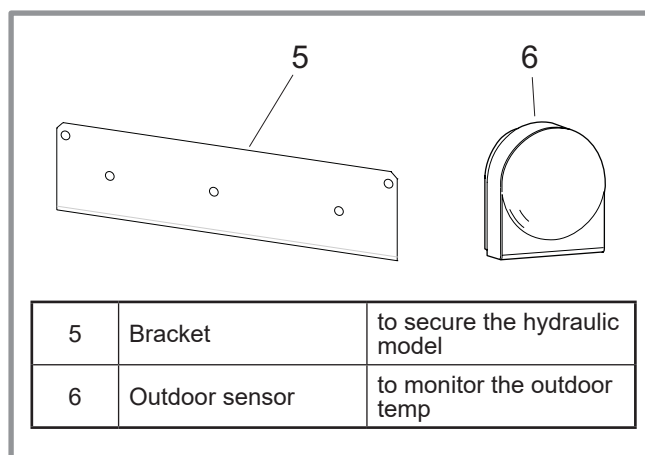


figure 11 - Accessories provided with the hydraulic unit



## 2.3 Installation of refrigerant connections

- ⚠ **Manipulate the pipes and made their crossing (slab or wall) with protective caps in place or after brazing.**
- ⚠ **Keep the protective caps or ends soldered to the commissioning of the appliance.**

The outdoor unit must be connected to the hydraulic unit **only with new copper pipes and connections** (Refrigerant quality), insulated separately.

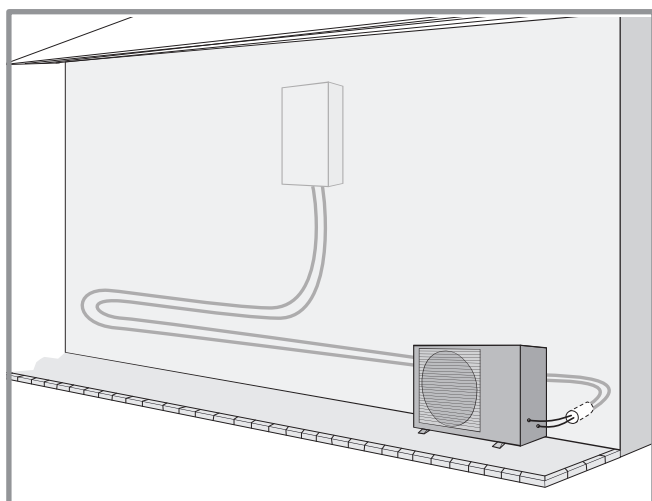
Respect the pipes diameters ([figure 18, page 19](#)).

Observe the maximum and minimum distances between the hydraulic unit and the outdoor unit ([figure 18, page 19](#)), the guarantee of the performances and the system's service life depend on this.

**The minimum length of the refrigerant connections is 5 m for correct operation.**

The appliance will be excluded from guarantee if it is used with refrigerant connections less than 5 m long (tolerance +/- 10%).

If the refrigerant connections are exposed to weathering or UV- and the insulation is not strong, it is necessary to provide protection.



**figure 12 - Recommended example of refrigerant connections disposition**

## 2.4 Installation of the outdoor unit

### 2.4.1 Installation precautions

- ☞ **The outdoor unit must only be installed outdoor (outdoors). If a shelter is required, it must have broad openings on the 4 walls and observe the installation clearances (figure 13).**
- Choose the location of the appliance after discussion with the client.
- Choose a site that is preferably sunny and sheltered from strong cold predominant winds.
- The unit must be easily accessible for future installation and maintenance work (page 16).
- Ensure that it is possible to make the connections to the hydraulic unit easily.
- The outdoor unit is able to withstand bad weather but avoid installing in a position where it is likely to be exposed to significant dirt or flowing water (under a defective gutter for example).
- Water may drain away from the outdoor unit when it is operating. Do not install the appliance on a paved terrace; choose a well-drained place (e.g. gravel or sand). If the installation is in an area where the temperature can be lower than 0°C for a long period, check that the presence of ice does not present any danger. A drainage pipe can also be connected to the outdoor unit (see figure 14, page 15).
- Nothing should obstruct the air circulation through the evaporator and from the fan (figure 13).
- Keep the outdoor unit away from heat sources and inflammable products.

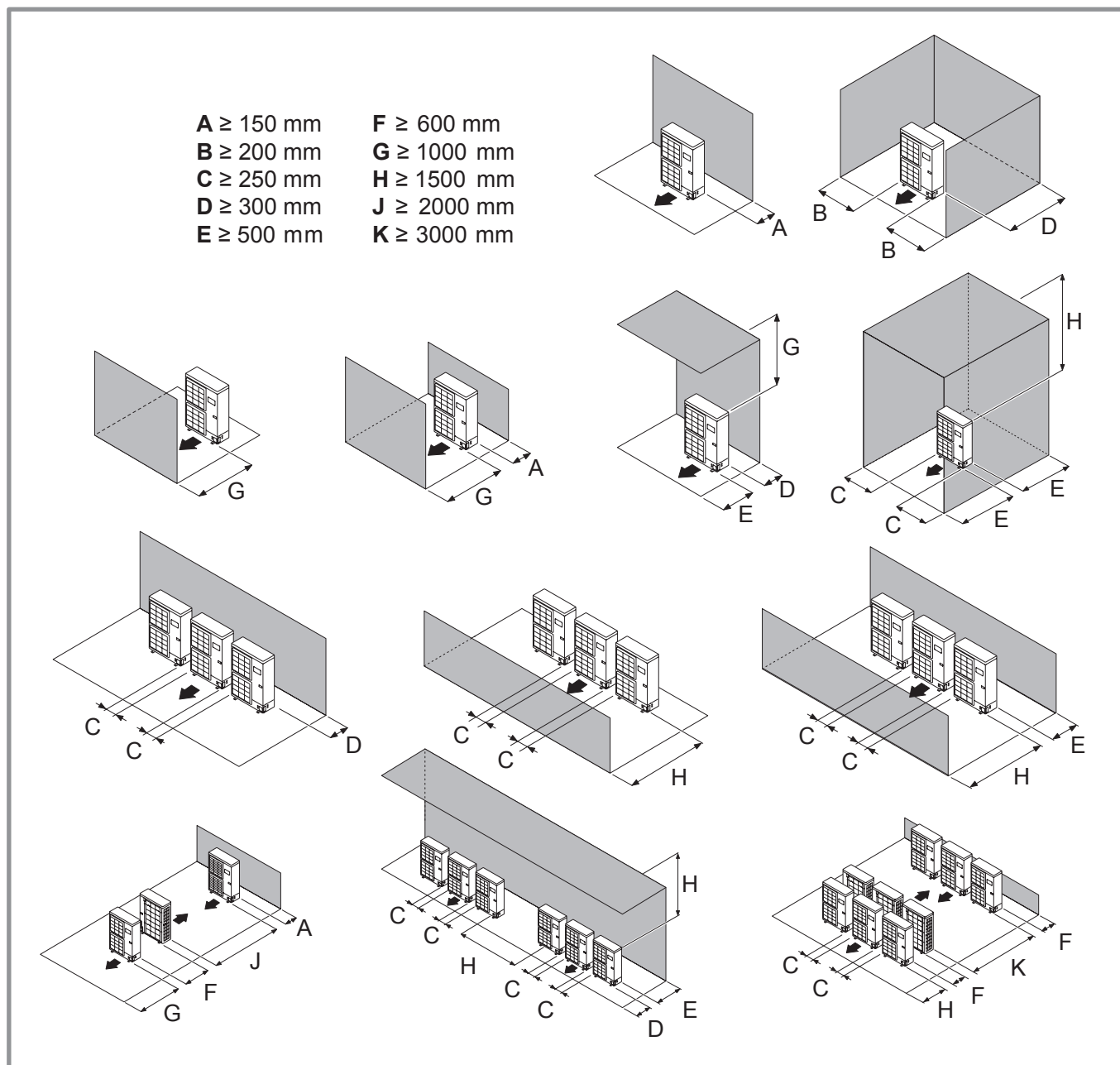


figure 13 - Minimum installation clearances around outdoor unit (all models)

- Make sure the appliance not disturb the surrounding area or users (noise level, draught generated, low temperature of the air being blown out, with the risk of freezing plants in its path).
- The surface on which the appliance is installed must:
  - be permeable (soil, gravel, etc),
  - support its weight easily,
  - provide a solid fixing and
  - not transmit any vibration to the dwelling. (Anti-vibratory blocks are available as an option).
- The wall bracket can not be used in conditions likely to transmit vibrations, ground position is preferred.

### 2.4.2 Outdoor unit positioning

The outdoor unit must be raised at least 50 mm above ground level. In areas prone to snow, this height should be increased but should not exceed 1.5 m (figure 12).

- Fasten the outdoor unit by means of screws and rubber tightening or toothed lock washers to avoid their coming loose.

#### ⚠ Warning

In the area with heavy snowfall, if the intake and outlet of outdoor unit is blocked with snow, it might become difficult to get warm and it is likely to cause of the breakdown.

Please construct a canopy and a pedestral or place the unit on high stand (local configured).

- Set the unit on a strong stand, such as one made of concrete blocks to minimize shock and vibration.
- Do not set the unit directly on the ground because it will cause trouble.

### 2.4.3 Condensate drain hose

(see figure 12).

- ⚠ **The outdoor unit can generate a large volume of water (called condensate).**

If the use of a discharge pipe is imperative:

- Use the elbow provided (C) to connect a 16mm-diameter hose for draining away the condensate.
- Use the stopper or stoppers provided (B) to block the opening of the condensate tank.

Allow for the condensate to flow away under the force of gravity (waste water, rain water, gravel bed).

- ⚠ **If the installation is made in an area where the temperature can be lower than 0°C for a long period, provide the drain pipe with a trace resistance to avoid it icing up. The trace resistance must heat not only the pipe but also the bottom of the appliance's condensate collection tank.**

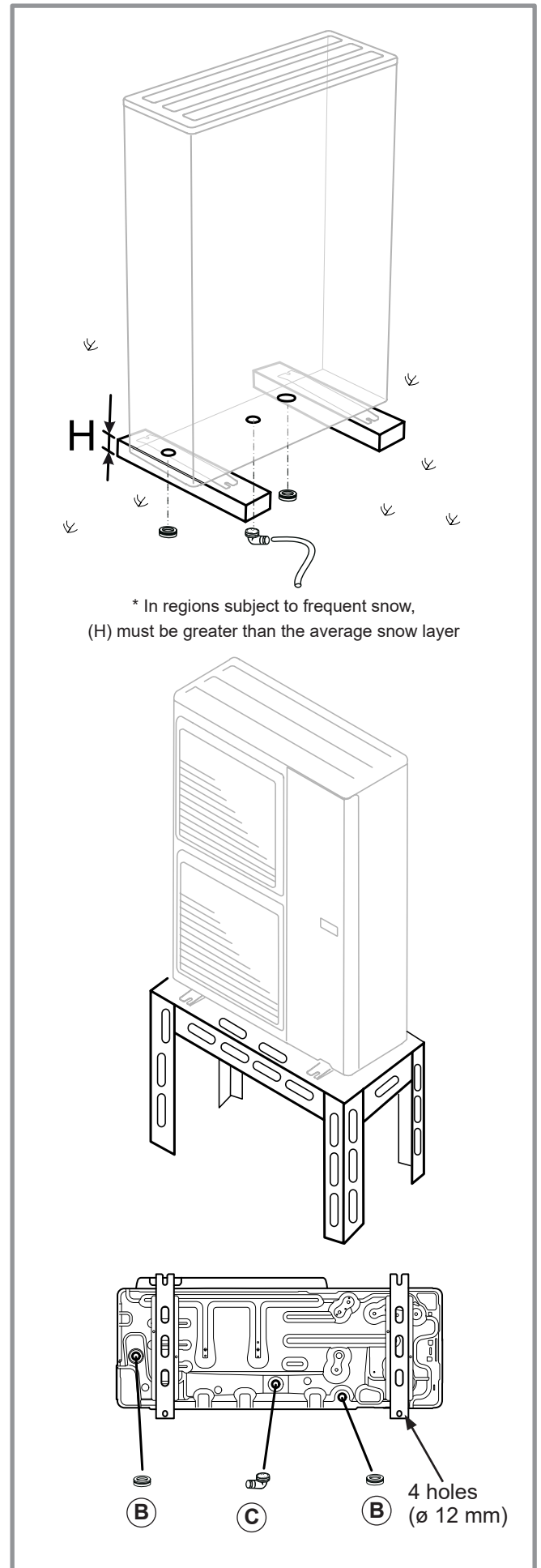
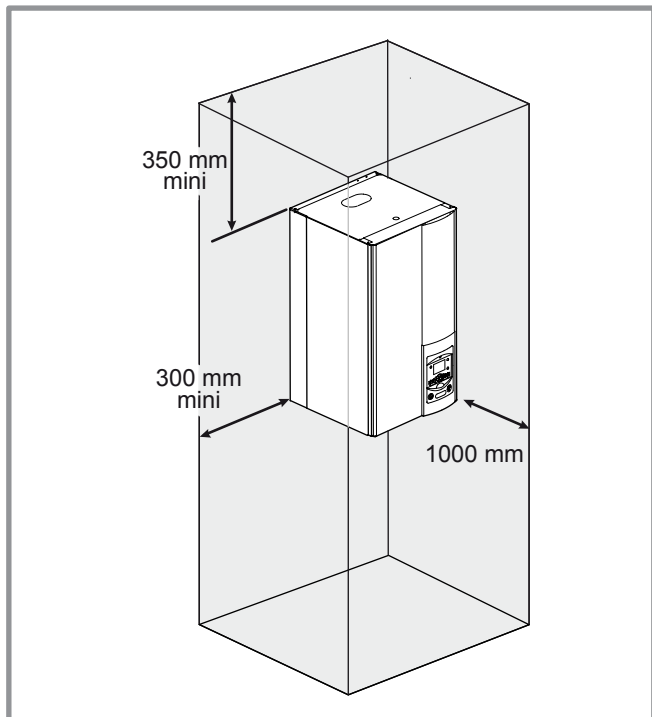


figure 14 - Positioning of the outdoor unit, draining away the condensate

## 2.5 Installing the hydraulic unit

### 2.5.1 Installation precautions

- Choose the location of the appliance after discussion with the client.
- The room in which the appliance operates must comply with the prevailing regulations.
- To facilitate maintenance and to allow access to the various components, we recommend that you provide sufficient space all around the hydraulic unit.



- In accordance with EN 378-1 -2017 standard (Refrigerating systems and heat pumps - Safety and environmental requirements), the system's hydraulic unit and all refrigeration connections passing through inhabited areas must comply with the minimum room volume requirements shown hereafter.

The minimum volume of a room (in m<sup>3</sup>) is calculated using the formula: "fluid fill load" (in kg) / 0.39.

Alternatively, you must ensure that

- the location has natural ventilation through another room where the combined volume of the two rooms is greater than "liquid fill load" (in kg) / 0.39 kg/m<sup>3</sup>. The opening between the two rooms must have a door clearance of at least 1 cm.
- or that the location is mechanically ventilated.
- Be careful not to bring inflammable gas near to the heat pump during its installation, in particular when it requires brazing. The appliances are not fireproof and should therefore not be installed in a potentially explosive atmosphere.
- To avoid condensation inside the condenser, remove the refrigerant circuit caps **only when completing the refrigerant connections**.
- If the refrigerant connection only occurs at the end of the installation, be sure that the refrigerant circuit caps\* remain in place and tight throughout the installation duration.

\* (hydraulic unit side and outdoor unit side).

- After every intervention on the refrigeration circuit and before final connection, take care to replace the plugs in order to avoid any pollution from the refrigeration circuit (The sealing with tape is prohibited).

### 2.5.2 Positioning the hydraulic unit

- Fix the support solidly (4 screws and plugs) to a flat, hard-wearing wall (not a light partition) ensuring that it is correctly levelled.
- Hook the appliance onto its support.

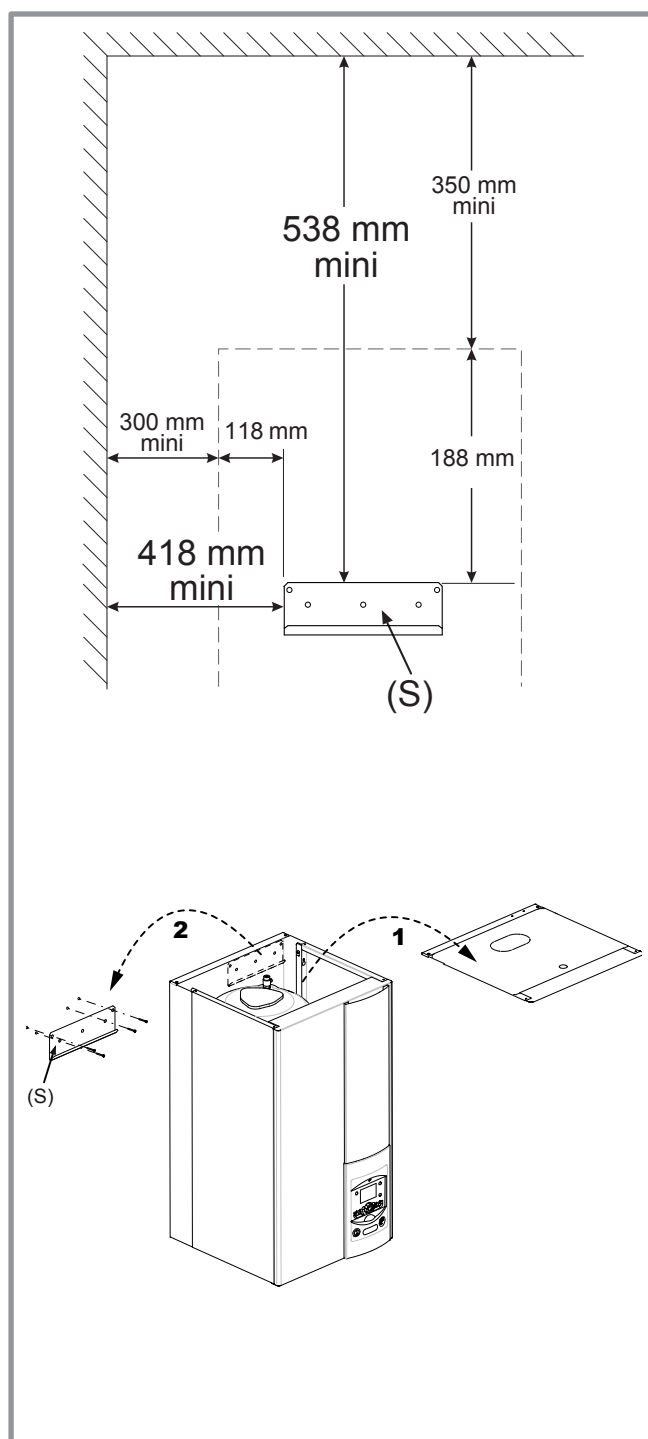


figure 15 - Mounting bracket

## 3 Refrigerant gas connection and filling the installation with gas

☞ **This appliance uses refrigerant R410A.**

Comply with the legislation for handling refrigerants.

### 3.1 Rules and precautions

☞ **Connections must be made the day of the filling the installation with gas (3.4, page 22).**

#### • Minimum necessary tools

- Set of manometers (*Manifold*) with hoses exclusively reserved for HFCs (Hydrofluorocarbons).
- Vacuum gauge with isolation valves.
- Vacuum pump specially for HFCs (use of a traditional vacuum pump is authorized if, and only if, it is fitted with a non-return valve on the suction side).
- Flaring tool, Pipe-cutter, Deburring tool, Wrenches.
- Refrigerant gas leak detector certified (sensitivity 5g/year).

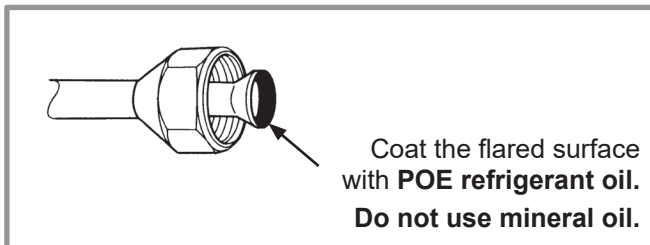
☞ **Provision on using tools that have been in contact with HCFCs (R22 for example) or CFCs.**

☞ **The manufacturer declines any liability with regard to the guarantee if the above instructions are not observed.**

#### • Flared connections

☞ **Lubrication with mineral oil (for R12, R22) is forbidden.**

- Only lubricate with polyolester refrigerant oil (POE). If POE is not available, fit without lubrication.



#### • Brazing on the refrigerant circuit (if necessary)

- Silver brazing (40% minimum recommended).
- Brazing only under dry nitrogen internal flux.

#### • Remarks

- After every intervention on the refrigerant circuit and before final connection, take care to replace the plugs in order to avoid any pollution from the refrigerant circuit.
- To eliminate any filings in the pipes, use dry nitrogen to avoid introducing any humidity that may adversely affect the appliances operation. In general, take every precaution to avoid humidity penetrating into the appliance.
- Proceed to insulate the "Gas" and "Liquid" pipes to avoid any condensation. Use pipe insulators resistant to temperatures over 90°C. In addition if the humidity level in areas where the refrigerant pipes are installed is expected to exceed 70%, protect the pipes with pipe insulators. Use an insulating material thicker than 15mm if the humidity level is 70~80%, and an insulating material thicker than 20mm if the humidity exceeds 80%. If the recommended thicknesses are

not observed under the conditions described above, condensation will form on the surface of the insulation material. Lastly, take care to use pipe insulators whose thermal conductivity is 0.045 W/mK or less when the temperature is 20°C. The insulation must be impermeable to resist the passage of steam during the defrosting cycles (fibreglass wool is prohibited).

### 3.2 Shaping the refrigerant pipes

#### 3.2.1 Bending

The refrigerant pipes must be shaped only on a bending machine or with a bending spring in order to avoid any risk of crushing or breaking them.

☞ **Warning !**

- Remove the insulation material locally to bend the pipes.
- Do not bend the copper to any angle over 90°.

Never bend pipes more than 3 times in the same position otherwise traces of fracturing may appear (from strain-hardening the metal).

#### 3.2.2 Creating the flarings

- Cut the pipe to an appropriate length with a pipe-cutter without deforming it.
- Carefully deburr it, holding the pipe towards the bottom to avoid introducing filings into the pipe.
- Remove the flared connection nut situated on the valve to be connected and slip the pipe into the nut.
- Proceed to flare, letting the pipe overflow the flaring tool.

After flaring, check the condition of the working radius (L). This must not show any scratch or trace of any fracturing. Also check the dimension (B).

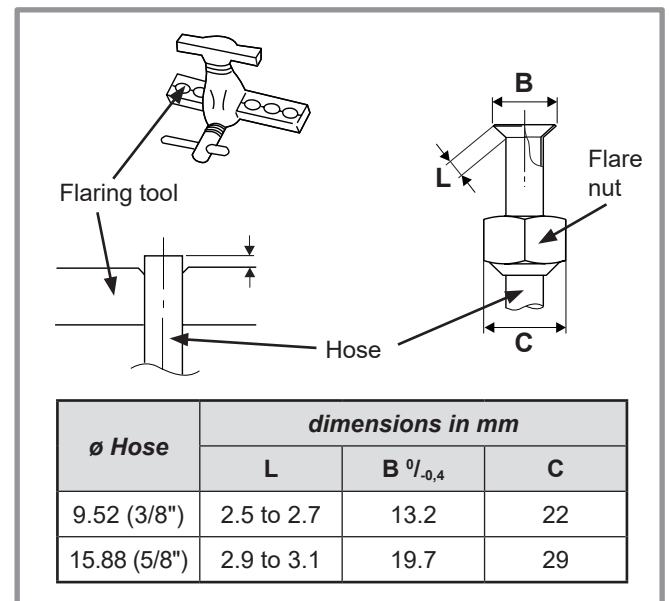


figure 16 - Flaring for flare connections

### 3.2.3 Accessing the hydraulic unit's refrigerant connections

- Remove the front panel (2 screws **A**).
- Remove the left-hand panel (2 screws **B**).

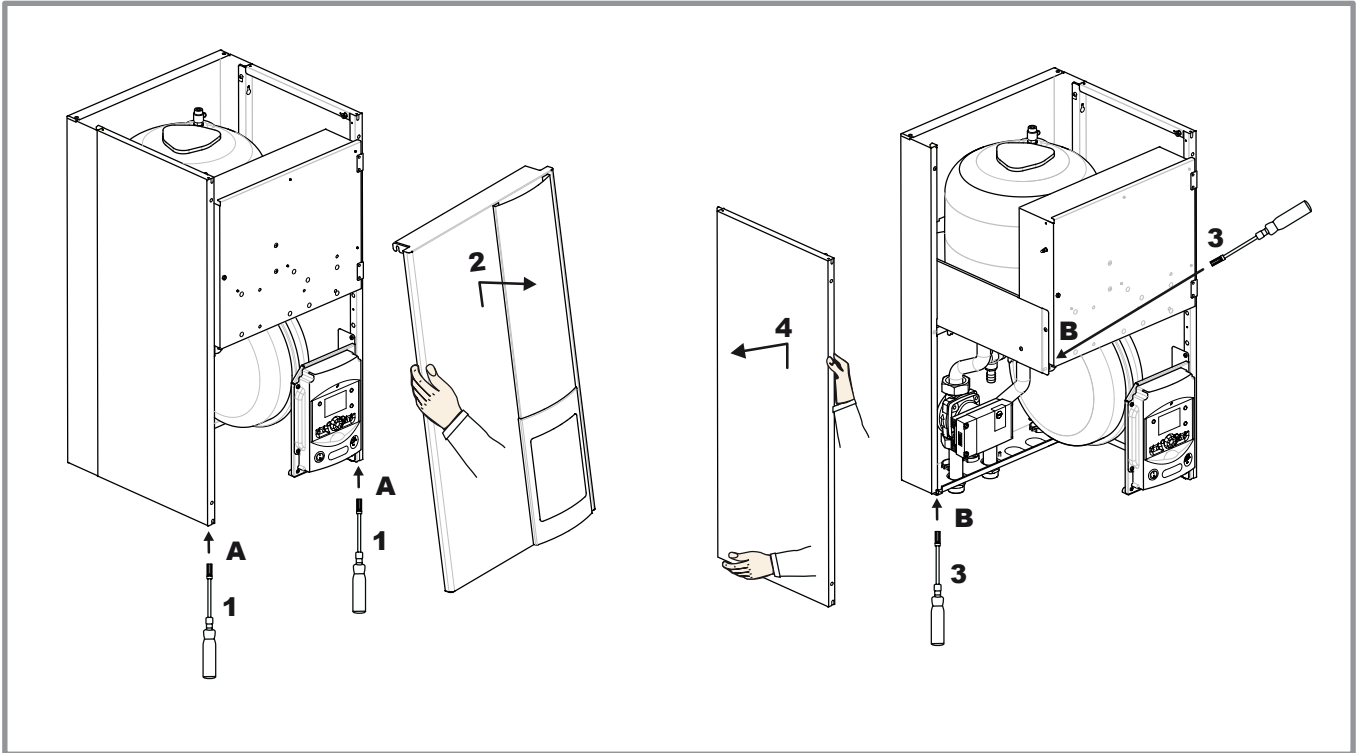


figure 17 - Removing the casing

HP model	Waterstage High Power single phase & 3-phase		
	gas	fluid	
<b>Outdoor unit connections</b>	5/8"	3/8"	
<b>Refrigeration connections</b>	<b>Diameter</b>	(D1) 5/8"	(D2) 3/8"
	<b>Minimum length (L)</b>	5	
	<b>Maximum length* (L)</b>	15	
	<b>Maximum length** (L)</b>	20	
	<b>Maxi level difference** (D)</b>	15	
<b>Hydraulic unit connections</b>	5/8"	3/8"	

\* : Without additional charge of R410A.

\*\* : Taking into account the possible additional load of refrigerant R410A (see para. "Additional charge", page 24).

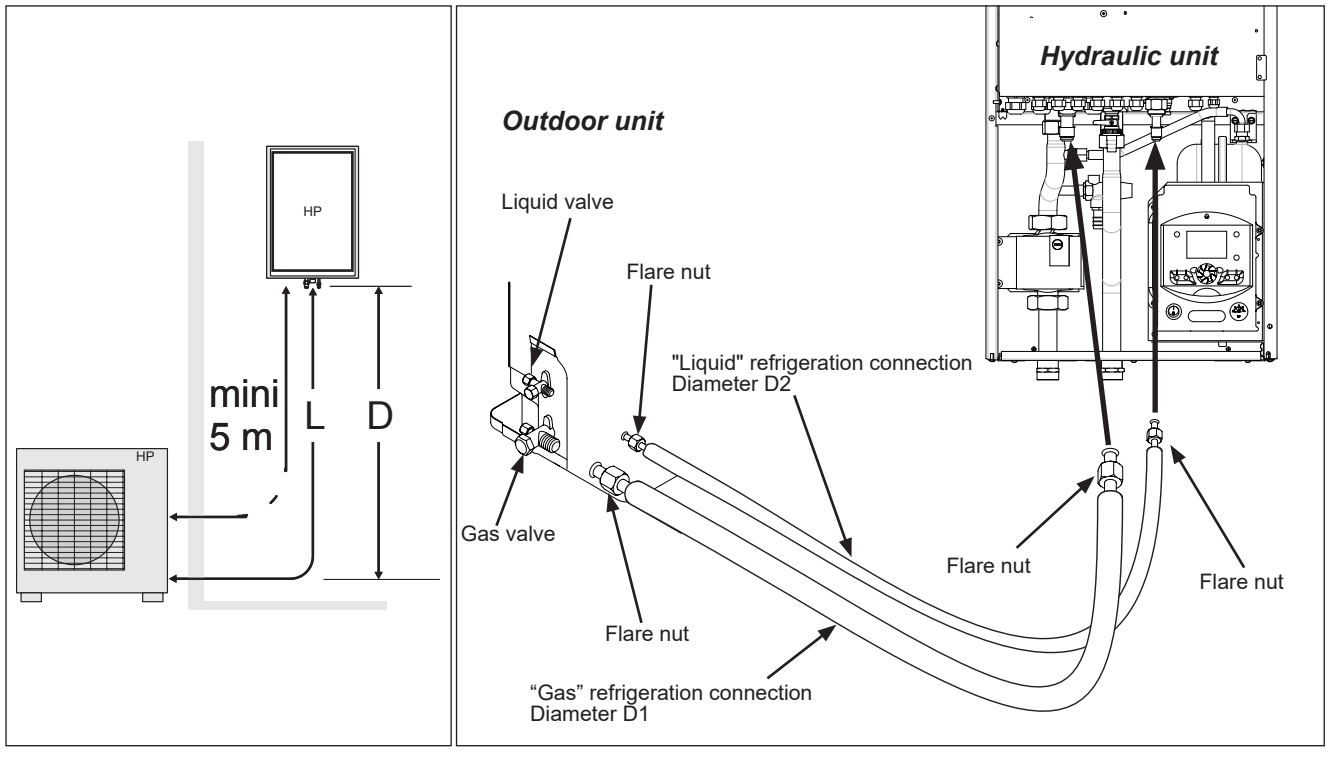


figure 18 - Connecting the flared connections (Pipe diameters and permissible lengths)



### 3.3 Check and connecting

☞ The refrigerant circuit is very sensitive to dust and humidity: check that the area around the connection is clean and dry before removing the plugs protecting the refrigerant connectors.

☞ **Indicative blowing value: 6 bar during 30 seconds minimum for connection of 20 m.**

**"Gas" connection control (large diameter).**

① Connect the "Gas" connection to the outdoor unit. Blow dry nitrogen into the "Gas" connection and observe this end:

- If water or impurities emerge, use a new refrigerant connection.

② Otherwise, perform the flare and connect immediately the refrigerant connection to the hydraulic unit.

**"Liquid" connection control (small diameter).**

③ Connect the "Liquid" connection to the outdoor unit. Blow dry nitrogen into "Gas" connection – condenser - "Liquid" connection assembly and Observe this end (Outdoor unit side).

- If water or impurities emerge, use a new refrigerant connection.

- Otherwise, perform the flare and connect immediately the refrigerant connection to the outdoor unit.

**Remarks :**

☞ Take particular care positioning the tube opposite its connector so as not to risk damaging the threads. A carefully aligned connector can be fitted easily by hand without much force being required.

- Remove the plugs from the pipes and the refrigeration connections.

- **Warning !** Avoid positioning the Gas pipe in front of the pump.

- Comply with the indicated tightening torques.

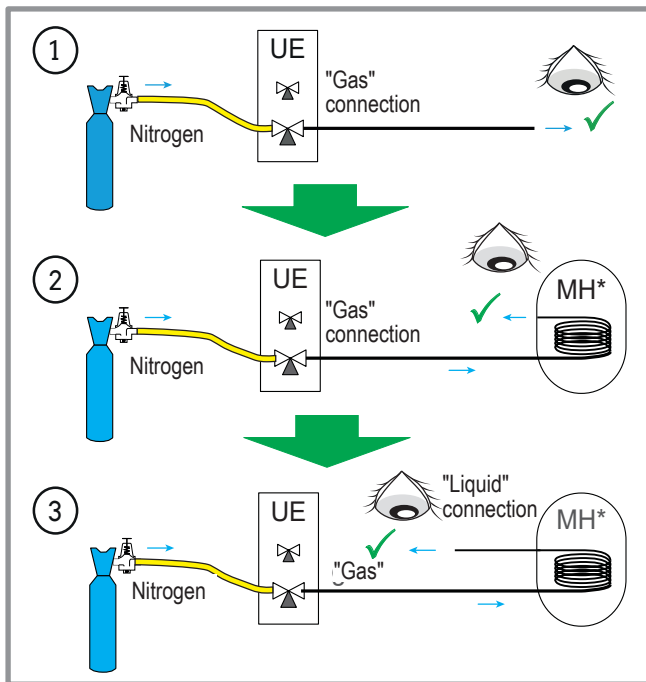


figure 20 - Refrigerant connections check

Holding wrench

Torque wrench

Designation	Tightening torque
Flare nut 9.52 mm (3/8")	32 to 42 Nm
Flare nut 15.88 mm (5/8")	63 to 77 Nm
Plug (A) 3/8"	20 to 25 Nm
Plug (A) 5/8"	30 to 35 Nm
Plug (B) 3/8", 5/8"	10 to 12 Nm

Plug (A) and (B) : see figure 21, page 23.

figure 19 - Tightening torque





### 3.4 Filling the installation with gas

- ☞ This operation is reserved for installers familiar with the legislation for handling refrigerants.
- ☞ Creating a vacuum with a vacuum pump is essential (see ANNEX 1).
- ☞ Never use equipment used beforehand with any refrigerant other than a HFC.
- ☞ Remove the refrigerant circuit caps only when building the refrigerant connections.

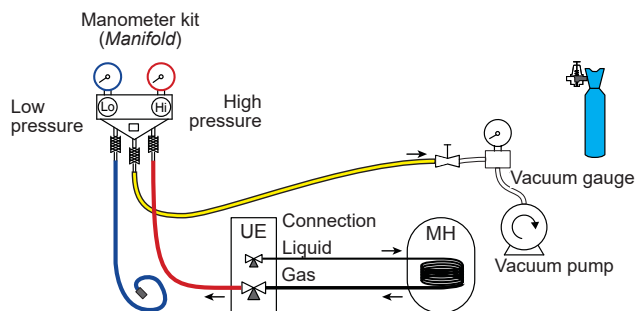
☞ **If the outdoor temperature is below +10°C:**

- You must use Method 3 (see ANNEX 2).
- It is advised to install a dehydrator filter (and highly recommended if the outdoor temperature is below +5°C).

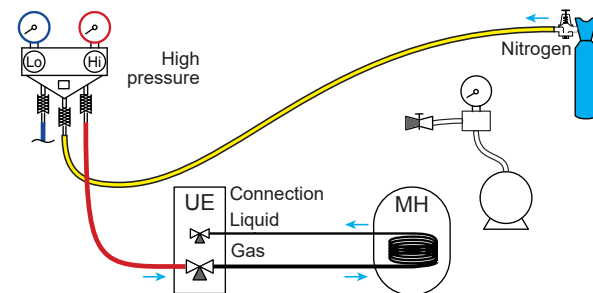
#### ANNEX 2 Method 3 empty

- Connect the high pressure hose to the *Manifold*, ("Gas" connection). A valve must be mounted on the flexible hose from the vacuum pump in order to isolate it.

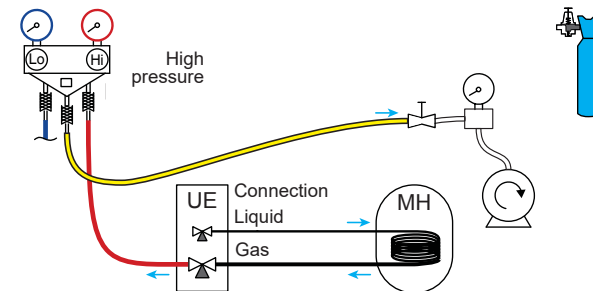
**a)** Create a vacuum until the desired value and maintain this value during 30 min (see table ANNEX 1),



**b)** Stop the vacuum pump, close the valve end of the service hose (yellow). Connect the hose to the expansion valve of the nitrogen bottle, inject 2 bars, close the flexible hose valve,



**c)** Reconnect the flexible hose to the vacuum pump, turn on and gradually open the hose valve.

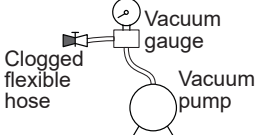


**d)** Repeat this at least three times.

☞ **Reminder :** It's strictly forbidden to perform these operations with refrigerant.

#### ANNEX 1 Method for calibration and control of a vacuum pump

- Check the oil level of the vacuum pump.
- Connect the vacuum pump with the vacuum gauge according to the scheme.



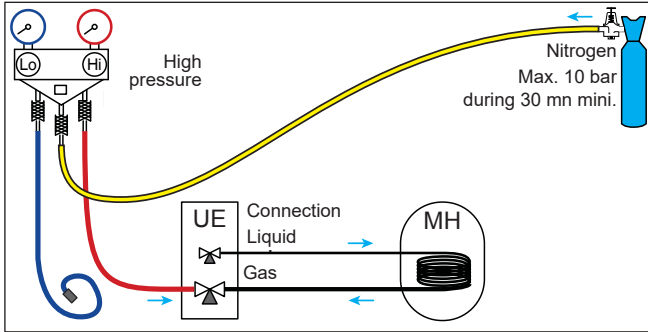
- Pump down during 3 minutes.
- After 3 minutes, the pump reaches its threshold value and the vacuum gauge needle does not move.
- Compare the obtained pressure with the value of the table. Depending on the temperature, this pressure must be less than the value indicated in the table.

=> If it's not the case, replace the gasket, flexible hose or the pump.

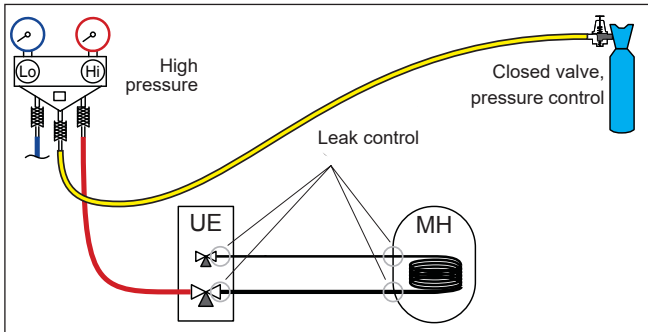
T °C	5°C < T < 10°C	10°C < T < 15°C	15°C < T
<b>Pmax</b>			
- bar	0.009	0.015	0.020
- mbar	9	15	20

### 3.4.1 Seal test

- Remove the protective plugs (**B**) from the charging hole (*Schrader*) in the "Gas" valve (large diameter).
- Connect the high pressure hose to the *Manifold*.
- Connect the bottle of nitrogen to the *Manifold* (Use only dry nitrogen type U).
- Pressurize the refrigerant circuit with nitrogen (10 bar maximum) ("Gas" connection – condenser - "Liquid" connection assembly).
- Let the circuit under pressure for 30 minutes.



- If pressure drop, get it down to 1 bar and look for leaks with a leak detector, repair and repeat the test.



- When the pressure is stable and leakage is excluded, drain nitrogen letting a pressure above atmospheric pressure (0.2 to 0.4 bar).

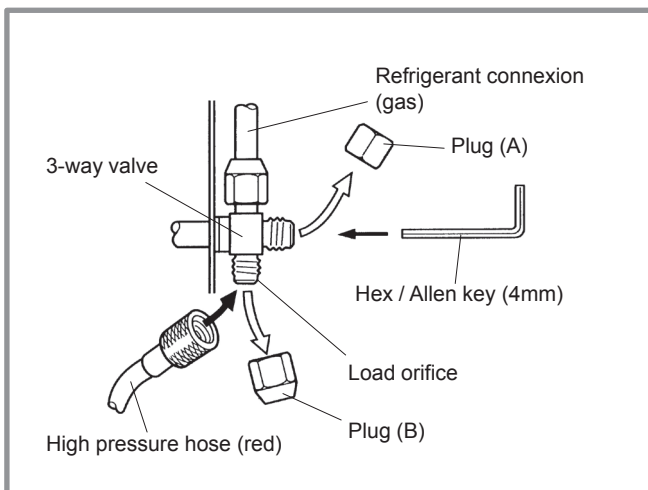
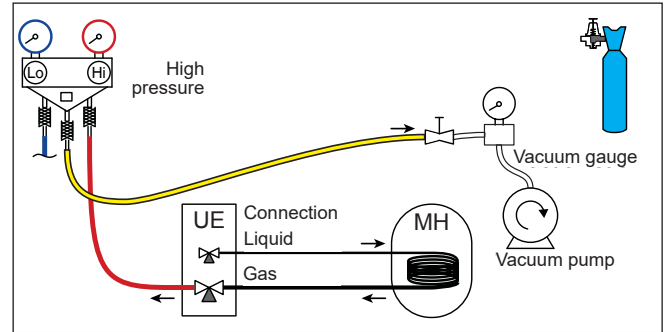


figure 21 - Connexion of the hose on the "Gaz" valve

### 3.4.2 Creating a vacuum

**⚠ The 3 empty method (ANNEX 2) is highly recommended for any installation especially when the outdoor temperature is below 10°C.**

- If necessary, calibrate the *Manifold* gauge to 0 bar. Adjust the vacuum gauge to the atmospheric pressure (around 1013 mbar).
- Connect the vacuum pump to the *Manifold*. Connect a vacuum gauge if the vacuum pump is not equipped.



- Create a vacuum until the residual pressure\* in the circuit falls below the value given in the following table (\* measured with the vacuum gauge).

T °C	5°C < T < 10°C	10°C < T < 15°C	15°C < T
<b>Pmax</b>			
- bar	0.009	0.015	0.020
- mbar	9	15	20

- Let the pump continue to operate for another 30 minutes minimum after reaching the vacuum.
- Close the *Manifold* valve and then stop the vacuum pump **without disconnecting any of the hoses in place.**

### 3.4.3 Filling the installation with gas

**⚠ If an additional charge is required, add the additional charge before filling the hydraulic unit with gas. Please refer to the para. "Additional charge", page 24.**

- Remove the access plugs (A) from the valve controls.
- First of all fully open the "Liquid" valve (small) and then the "Gas" valve (large) using a hex key (counterclockwise direction) without forcing excessively against the stop.
- Remove the hose rapidly to the *Manifold*.
- Refit the 2 original caps (be sure they are clean) and tighten them to the recommended tightening torque (figure 19, page 20). The sealing is performed in the caps only metal to metal.

The outdoor unit does not contain any additional refrigerant, enabling the installation to be purged. Flushing is strictly forbidden.

### 3.4.4 Sealing test

Once the refrigeration circuit has been gassed as described above, check that all the refrigeration connectors are gas-tight (4 connectors).

The sealing test must be performed with an approved gas detector. If the flarings have been made correctly, there should be no leaks.

☞ **If there is a leak:**

- Bring the gas into the outdoor unit (pump down).
- Make the connection again.
- Repeat the commissioning procedure.

### 3.4.5 Additional charge

	<b>50 g of R410A per additional meter</b>	
Length of the connections	15 m	20 m max.
Additional charge	none	250 g

The charge in the outdoor units corresponds to the maximum distances between the outdoor unit and the hydraulic unit defined in page 19. If the distances are greater, an additional charge of R410A is required. The additional charge depends on the distance between the outdoor unit and the hydraulic unit for each type of appliance. The additional charge of R410A must necessarily be made by an approved refrigeration engineer.

• **Example of additional charge :**

An outdoor unit 17 m away from the hydraulic unit will require an additional charge of :

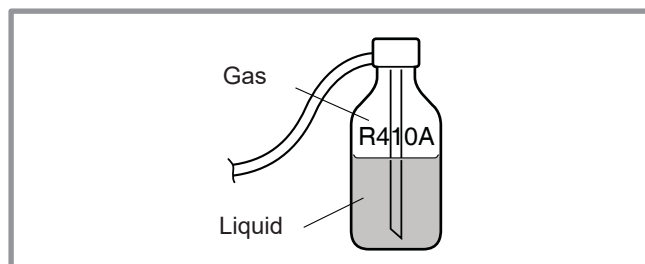
$$\text{Additional charge} = (17 - 15) \times 50 = 100 \text{ g.}$$

The charge must be introduced after creating the vacuum and before the hydraulic unit is filled with gas, as follows :

- Disconnect the vacuum pump (yellow hose) and connect a bottle of R410A instead **in the liquid extraction position.**
- Open the bottle's valve.
- Bleed the yellow hose by loosening it slightly on the *Manifold* side.
- Place the bottle on scales with a minimum accuracy of 10 g. Note the weight.
- Carefully open the blue valve slightly and check the value shown on the scales.
- As soon as the value displayed has dropped by the value for the calculated additional charge, close the bottle and disconnect it.
- Then rapidly disconnect the hose connected to the appliance.
- Proceed to fill the hydraulic unit with gas.

☞ **Warning**

- Only use R410A !
- Only use tools suitable for R410A (set of manometers).
- Always charge in the liquid phase.
- Never exceed the length or the maximum difference in level.





**figure 22 - Gas bottle R410A**

### 3.4.6 Pump down operation (Refrigerant collecting operation) outdoor unit

- ☞ Ensure that **the general electrical power supply** has been cut off before starting any repair work.
- ☞ ⚠ **Stored energy: after disconnecting power supplies wait 1 minute before accessing the internal parts of the equipment.**

Perform the following procedures to collect the refrigerant.

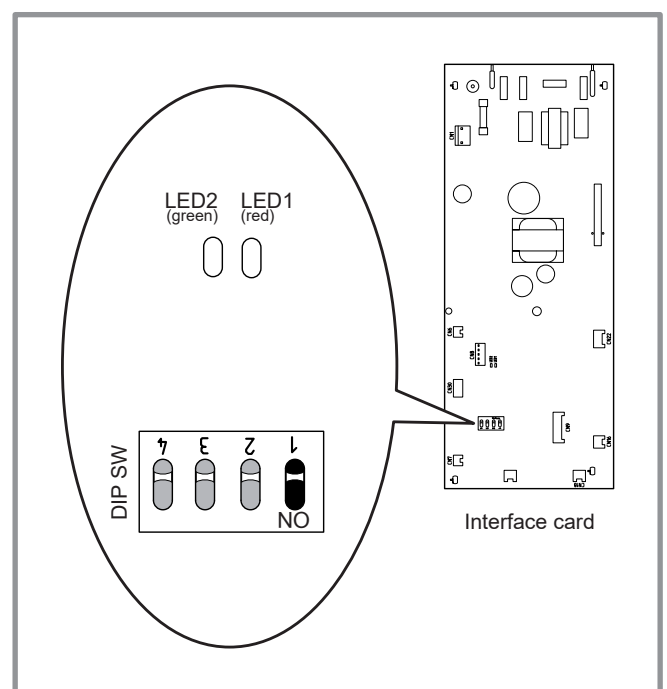
- **1-** Turn OFF the start/stop switch (ref. 3, figure 8, page 10). Disconnect the outdoor units power supply.
- **2-** Remove the front panel. Open the power control box. Then turn **ON** the **DIP SW1** on the interface board,
- **3-** Reconnect the power supply. Turn ON the start/stop switch. (Green and Red LED on the board start flashing ; 1 sec. on / 1 sec. off repeated). The outdoor unit begins cooling operation about 3 minutes after switching ON.
- **4- Rapidly:** Set the parameter **7700 (Relay output QX1)** to **ON**. => The pump works normally.

*Reminder: Press **OK**. Hold on the key  for 3s and select the level of access\* used with the aid of the knob . Confirm with the key **OK**.*

- \* Choose "Specialist" level / Inputs / outputs test.
- **5-** Close the liquid valve on the outdoor unit 30 s **maximum** after operation starts.
- **6-** Close the gas valve on the outdoor unit as soon as the pressure is lower 0.02 bar relative reading on the Manifold or 1-2 minutes after closing the liquid valve, while the outdoor unit keeps running.
- **7-** Disconnect the power supply.
- **8-** The refrigerant collecting operation is over.

Remarks:

- The pump down operation cannot be activated even if **DIP SW1** is changed while heat pump's power is **ON**.
- Do not forget to turn back **DIP SW1** on the interface board to **OFF**, after the pump down operation has been completed.
- Select the "AUTO" heating mode.
- When the pump down operation is repeated, temporarily turn OFF the start/stop switch after opening the closed valves (both liquid and gas).



**figure 23 - Location of DIP switches and LED on the hydraulic unit interface card**

## 4 Hydraulic connecting

### ☞ General

The connection must comply with good trade practice according to local building regulations.

Reminder: Seal everything when fitting in accordance with prevailing trade practice for plumbing work:

- Use suitable seals (fibre seals, o-rings).
- Use Teflon tape or hemp.
- Use sealing paste (synthetic depending on the case).

Use glycol if the flow temperature set [908-909 Settings] <10°C. If you are using a glycol/water mix, provide for an annual check on the quantity of glycol. Use monopropylene glycol only. The recommended concentration is 30% minimum. **Never use monoethylene glycol.**

☞ **In certain installations, the presence of different metals can cause corrosion problems; the formation of metal particles and sludge in the hydraulic circuit is then seen.**

☞ **In this case, it is advisable to use a corrosion inhibitor in the proportions indicated by its manufacturer.**

- Please refer to the chapter "Treatment of domestic and heating water" in our price catalogue.

☞ **It is also necessary to ensure that the treated water does not become aggressive.**

### 4.1 Connecting to the Heating circuit

#### 4.1.1 Rinsing out the installation

Before connecting the hydraulic unit to the installation, **rinse out the heating system correctly** to eliminate any particles that may affect the appliance's correct operation.

Do not use solvents or aromatic hydrocarbons (petrol, paraffin, etc.).

In the case of an old installation, provide a sufficiently large decanting pot with a drain on the return from the boiler and at the lowest point in the system in order to collect and remove the impurities.

Add an alkaline product to the water and a dispersant.

Rinse the installation several times before filling it definitively.

#### 4.1.2 Connecting

The heating circulating pump is built into the hydraulic unit.

Connect the central heating pipes to the appliance, complying with the direction of circulation.

The pipe between the heat pump and the heat collector must be at least one inch in diameter (26x34 mm).

Calculate the diameter of the pipes according to the flow rates and the lengths of the hydraulic systems.

Tightening torque: 15 to 35 Nm.

Use union connectors to facilitate removing the hydraulic unit.

Preferentially use connection hoses to avoid transmitting noise and vibrations to the building.

Connect the drains from the drain valve and the safety valve to the main sewer system.

Verify the correct functioning of the expansion system. Control the vessel pressure (precharge 1 bar) and the safety valve setting.

The flow of the installation must be at least equal to the minimum value noted in the characteristics table (section 1.3, page 5). Do not instal any regulating appliance (without those present in our configurations) who's reduce or stop the flow through the hydraulic unit.

### 4.1.3 Volume of the heating system

**You must respect the minimum installation water volume.** Install a buffer tank on the return of the heating circuit in case of lower volume than this value. In the case of a system equipped with Thermostatic(s) valve(s), it is necessary to ensure that this minimum water volume can flow.

HP	Minimum volume in liters BY CIRCUIT (without HP)		
	Obligation fan-coil	Recommendation Radiator	Recommendation Heating-cooling floor
High Power 112 Single Phase High Power 112 3-Phase	55	50	25
High Power 140 Single Phase High Power 140 3-Phase	74	66	35
High Power 160 3-Phase	87	80	44

### 4.2 Filling and purging the installation

Check the pipe fixings, the tightness of the connectors and the stability of the appliance.

Check the direction in which the water is circulating and that all the valves open.

Proceed to fill the installation.

Do not operate the circulating pump while filling. Open all the drain valves in the installation and the bleeder valve for the hydraulic unit (**P**) to remove the air contained in the conduits.

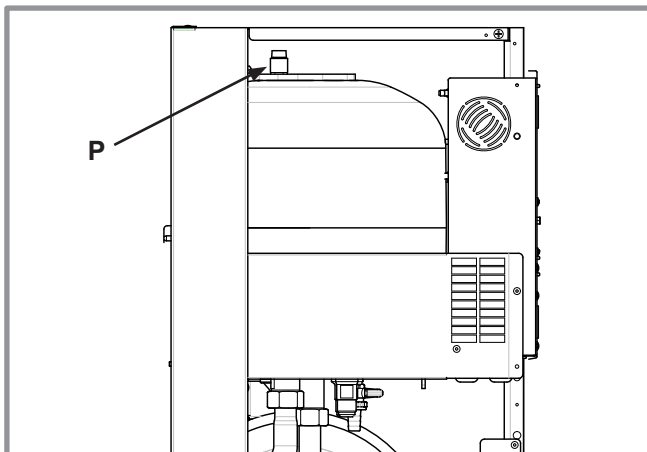
Close the drain and bleeder valves and add water until the pressure in the hydraulic circuit reaches 1 bars.

Check that the hydraulic circuit has been purged correctly.

Check there is not a leak.

After the "Commissioning", [page 38](#), once the machine has started, purge the hydraulic unit again (2 litres of water).

- ☞ **Precise filling pressure is determined by the manometric height of the installation.**



**figure 24 - Hydraulic unit bleeder valve**

### 4.3 Heating circulation pump speed settings

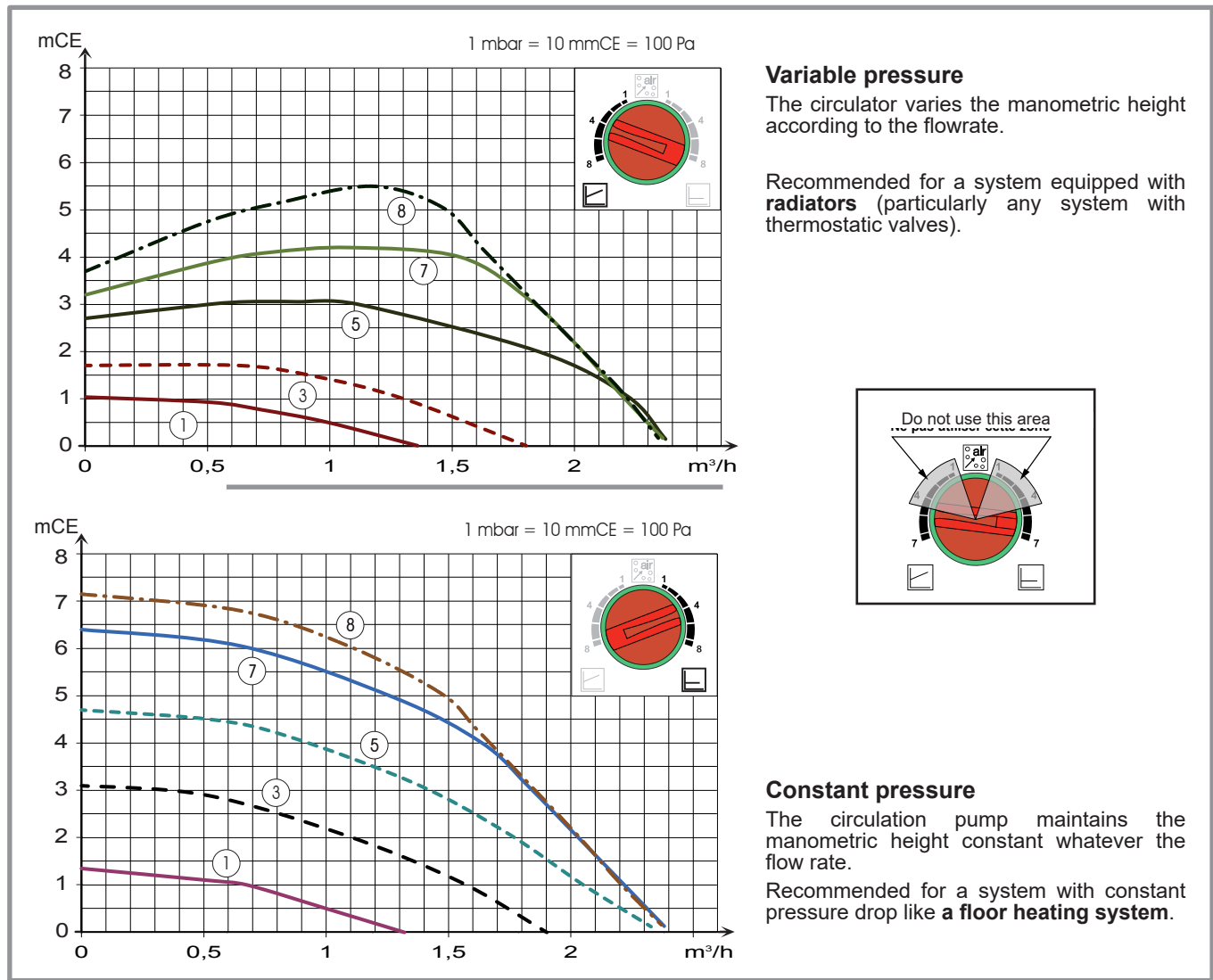
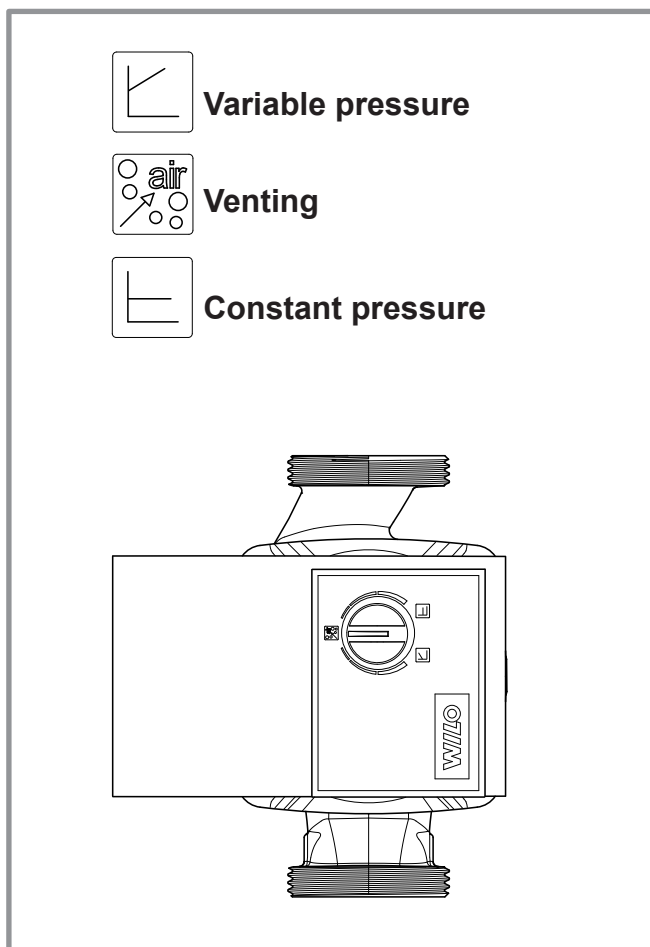


figure 25 - Hydraulic pressures and flow rates available

	<b>OFF</b>	LED Off: The pump does not work, no electrical power.
		Green LED on: The pump works normally.
	<b>10 min.</b>	Green LED blink: Venting operating mode (10 minutes).
	<b>Auto Test</b>	Green/Red LED blink: Operating error with automatic reboot.
		Red LED blink: Operating error.

figure 26 - Operation signals with the HP circulator





**figure 27 - Pump dial**

Circulation pump sticking or blocked:

If the motor is blocked, a start cycle is launched.

If the motor remains blocked it will be permanently stopped.

- ☞ **Cut off the electricity supply from the circulation pump for 30 seconds in order to release and authorise another start cycle.**

# 5 Electrical connections

Ensure that the general electrical power supply has been cut off before starting any repair work.

## 5.1 General

### 5.1.1 Characteristic of the electrical supply

The electrical installation must be conducted in accordance with the prevailing regulations.

The electrical connections must only be made when all the other fitting operations have been completed (fixing, assembly, etc.).

**Warning !**

The contract concluded with the energy provider must be sufficient not only to cover the heat pump's power but also the combined sum of all the appliances likely to be operating at the same time. When the power is too low, check with your energy provider the value subscribed to in your contract.

Never use a socket for the power supply.

The heat pump must be supplied directly (without external switch) with power by special protected leads from the electric panel via 2-pole circuit breakers specially dedicated to the heat pump, Curve C for the outdoor unit, curve C for the electrical heating and domestic water back-ups (see tables on page 31).

The electrical installation must necessarily be equipped with a 30mA differential protection.

This appliance is designed to operate under a nominal voltage of 230 V or 400 V, +/- 10%, 50 Hz (according to model).

### 5.1.2 General remarks on electrical connections

It is essential to maintain the live-neutral polarity when making the electrical connections.

Rigid wires are preferable for fixed installations, particularly in a building.

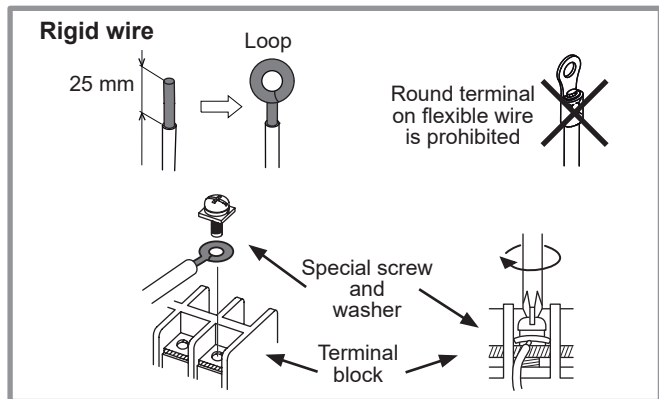
Tighten the cables using the cable glands to prevent the conductors from disconnecting accidentally.

Connection to Earth and Earth bonding continuity are essential.

### • Connecting to screw terminals

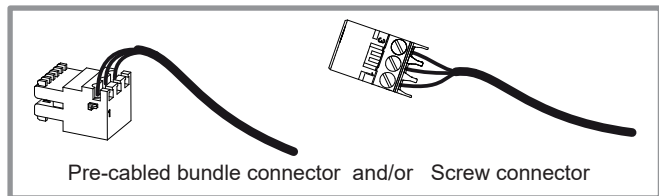
☞ **The use of round terminal or the ends is prohibited**

- Always select a rigid wire that complies with the prevailing standards.
- Strip away around 25 mm from the end of the wire.
- With round end pliers, form a loop with a diameter corresponding to the tightening screws on the terminal.
- Tighten the terminal screw firmly onto the loop created. Unsufficient tightening can cause overheating, leading to breakdown or even a fire.



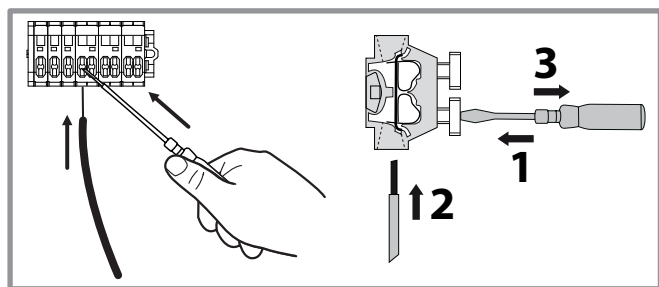
### • Connecting to regulation cards

- Remove the corresponding connector and make the connection.



### • Connecting to spring terminals

- Strip away around 10 mm from the end of the wire.
- Push the spring with a screwdriver so that the wire enters the cage.
- Slide the wire into the opening provided for this purpose.
- Remove the screwdriver and then check that the wire is jammed in the cage by pulling on it.



### 5.1.3 Overview of all the electrical connections

The wiring diagram for the hydraulic unit is shown in detail on figure 46, page 63.

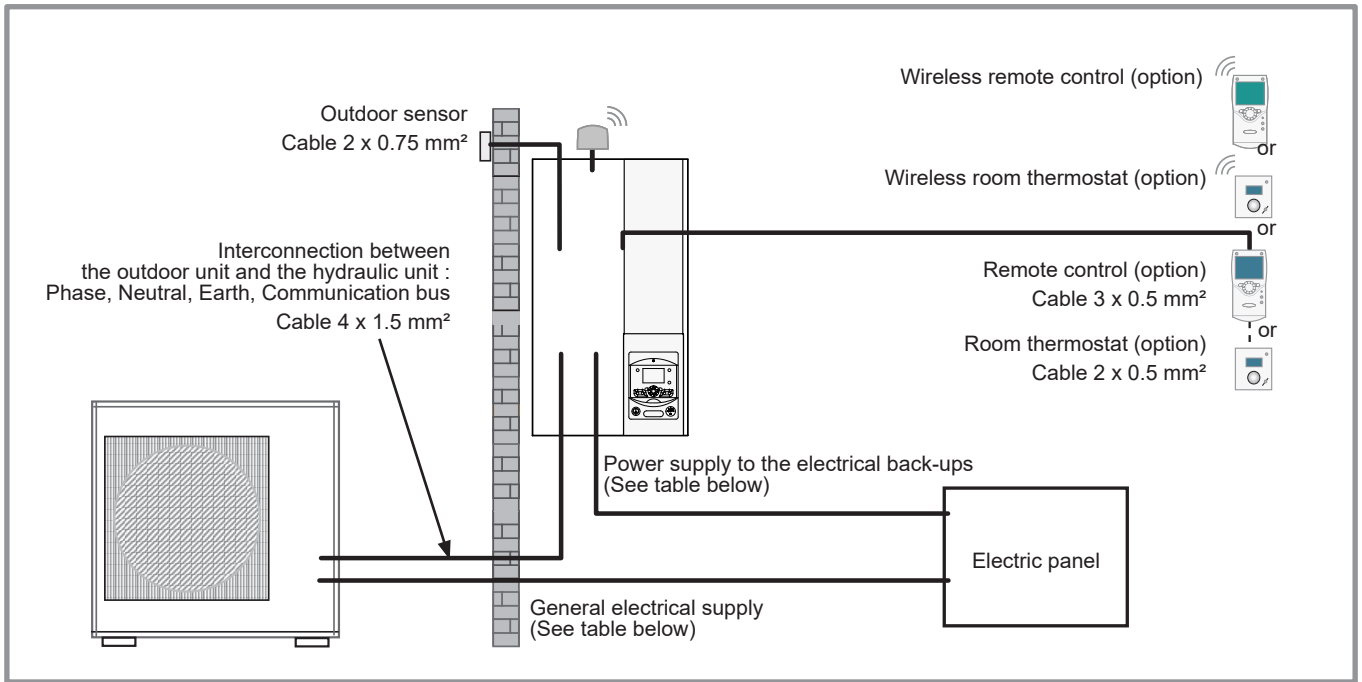


figure 28 - Overall layout of the electrical connections for a simple installation (1 heating circuit)

## 5.2 Cable section and protection rating

The cable sections are given for information purposes only and do not exempt the installer from checking that these sections correspond to the requirements and comply with the prevailing standards.

### • Power supply to outdoor unit

<i>Heat pump (single phase)</i>		<i>Electricity supply 230 V - 50 Hz</i>	
<i>Model</i>	<i>Maxi. power absorbed</i>	<i>Cable connection (phase, neutral, earth)</i>	<i>Curve C circuit breaker size</i>
High Power 11 single phase	5060 W	3 x 6 mm <sup>2</sup>	32 A
High Power 14 single phase	5750 W		
<i>Heat pump (3-phase)</i>		<i>Electricity supply 400 V - 50 Hz</i>	
<i>Model</i>	<i>Maxi. power absorbed</i>	<i>Cable connection (3 phases, neutral, earth)</i>	<i>Curve C circuit breaker size</i>
High Power 11 3-phase	5865 W	5 x 2.5 mm <sup>2</sup>	20 A
High Power 14 3-phase	6555 W		
High Power 16 3-phase	7245 W		

### • Interconnection between the outdoor unit and the hydraulic unit

The hydraulic unit is powered by the outdoor unit by means of a cable with 4 x 1.5 mm<sup>2</sup> (phase, neutral, earth, communication bus).

### • Power supply to the electrical back-ups

The hydraulic unit contains two stages of electrical back-ups installed in a heat exchange tank.

<i>Heat pump (HP)</i>	<i>Electrical back-ups</i>		<i>Power supply to the electrical back-ups</i>	
<i>Model</i>	<i>Power</i>	<i>Nominal current</i>	<i>Cable connection</i>	<i>Curve C circuit breaker size</i>
High Power single phase	2 x 3 kW	26.1 A	3 x 6 mm <sup>2</sup>	32 A
High Power 3-phase	9 kW	3 x 13 A	4 x 2.5 mm <sup>2</sup>	20 A

☞ Ensure that the general electrical power supply has been cut off before starting any repair work.

### 5.3 Electrical connections on the single phase outdoor unit side

Access to the connection terminals:

- Remove the front panel. Remove the screws and the front panel.

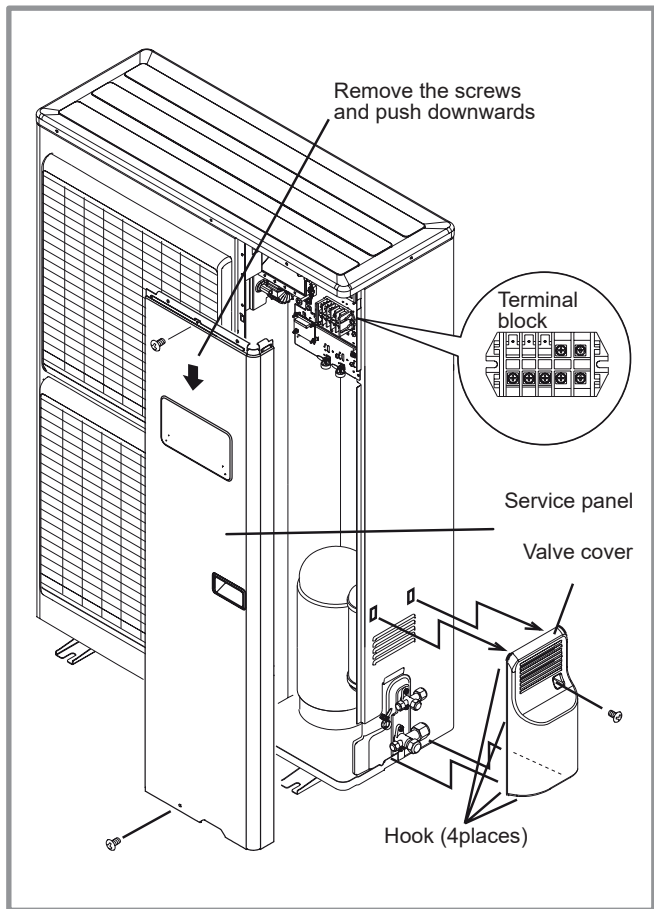


figure 29 - Access to single phase outdoor unit's terminal block

- Make the connections in accordance with the diagram figure 38, page 37.

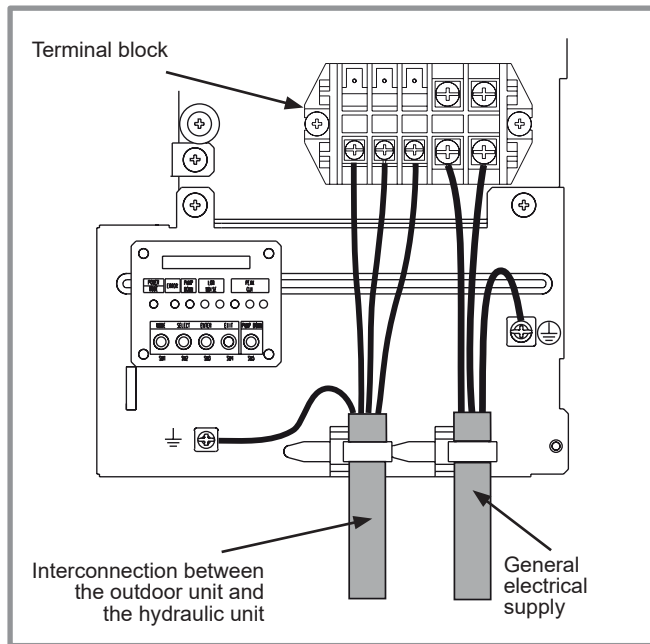


figure 30 - Connections to single phase outdoor unit's terminal block

- Use cable clamps to prevent the conductors from being disconnected accidentally.
- Use the mounting plate to hold the cables against the insulating plate.

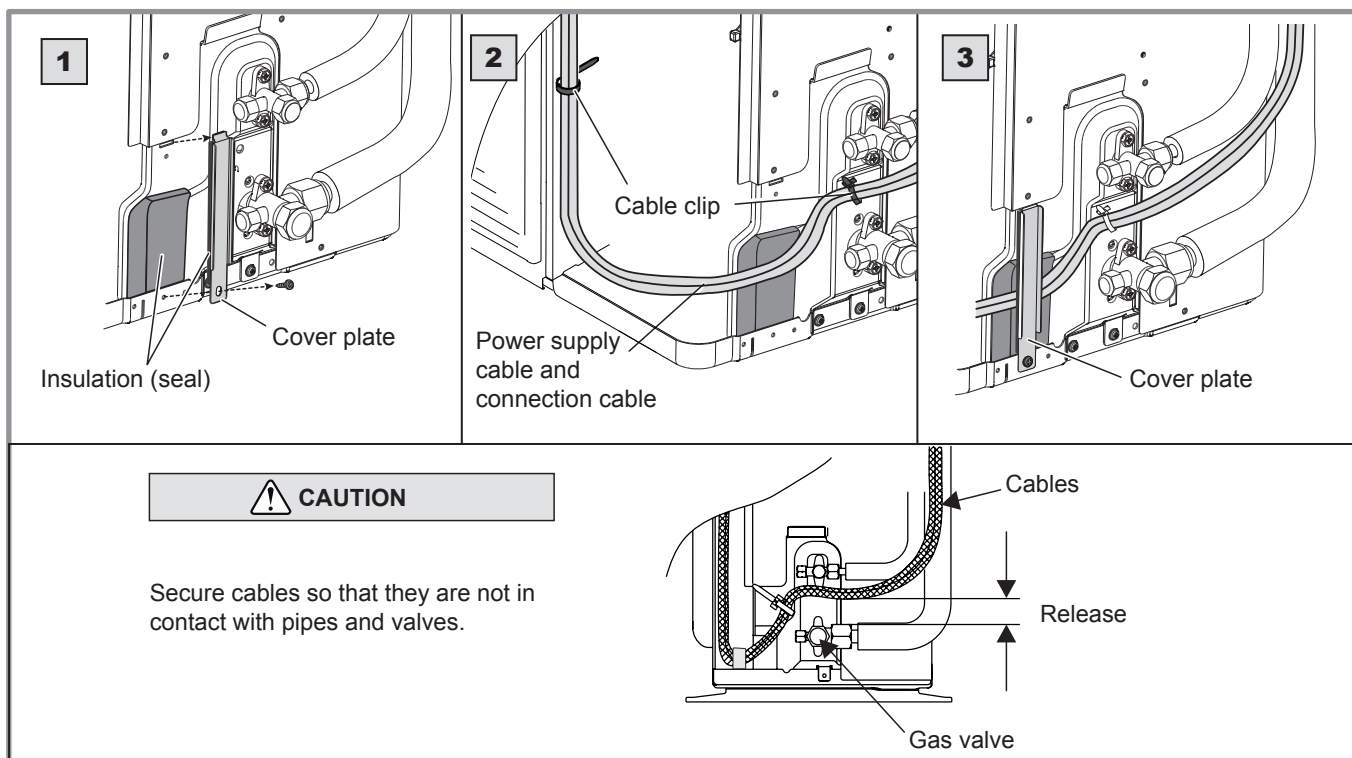
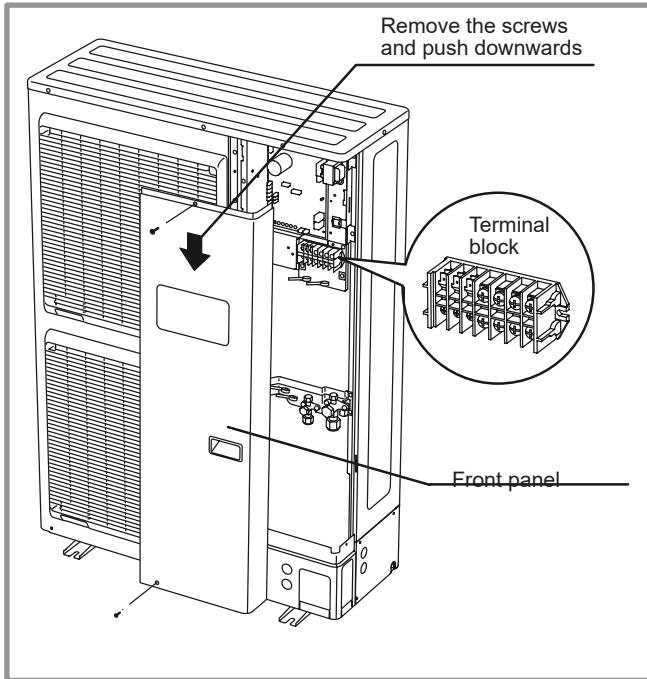


figure 31 - Finalisation of connection to single phase outdoor unit

### 5.4 Electrical connections on the 3-phase outdoor unit side

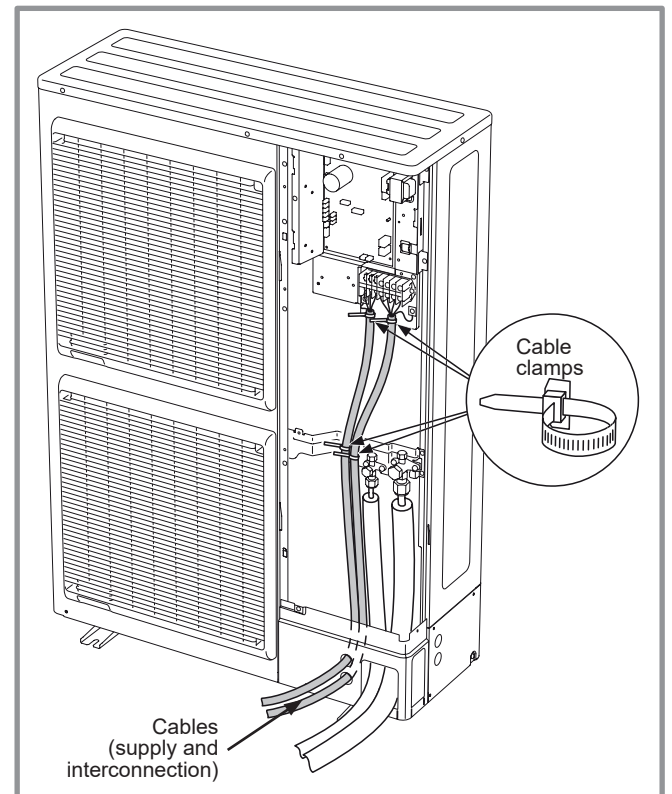
Access to the connection terminals:

- Remove the front panel. Remove the screws and the front panel.



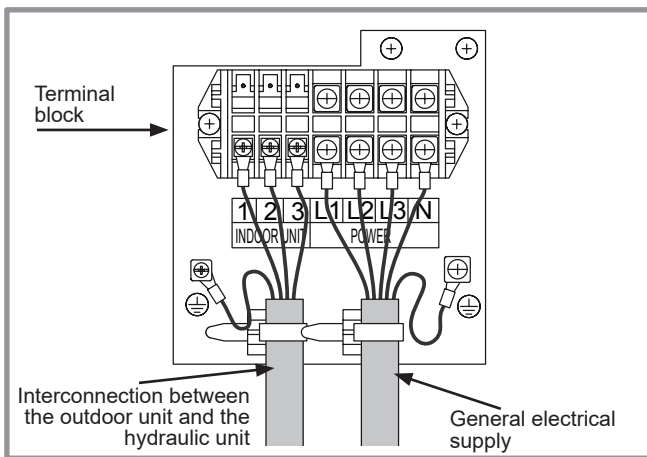
**figure 32 - Access to 3-phase outdoor unit's terminal block**

- Use cable clamps to prevent the conductors from being disconnected accidentally.
- Fill in the space where the cables enter the outdoor unit with the insulating plate.

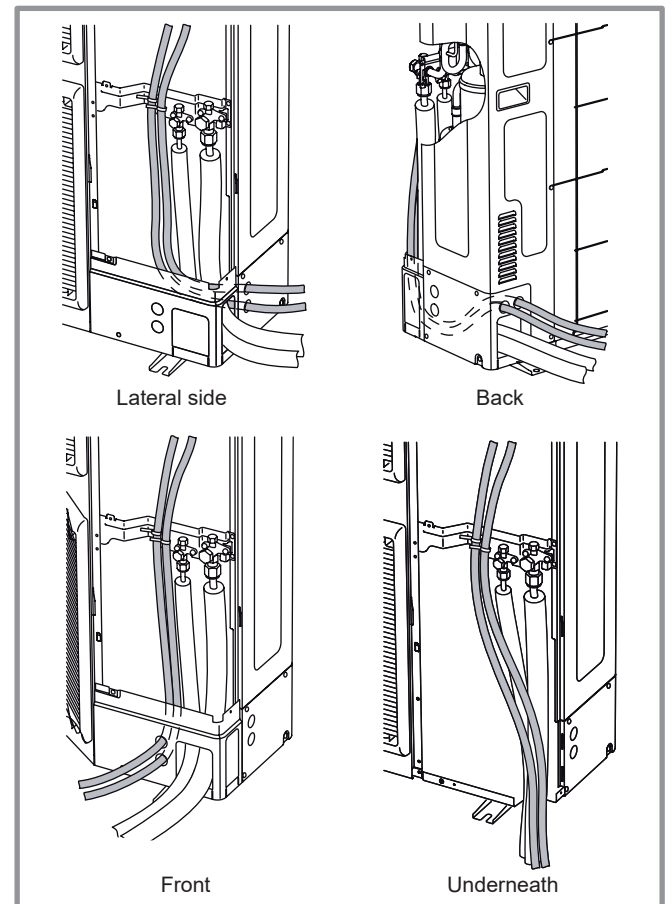


**figure 34 - Finalisation of connection to 3-phase outdoor unit**

- Make the connections in accordance with the diagram figure 38, page 37.



**figure 33 - Connections to 3-phase outdoor unit's terminal block**



**figure 35 - Location of electrical cables and refrigeration connections to 3-phase outdoor unit**

## 5.5 Electrical connections on the hydraulic unit side

Access to the connection terminals:

- Remove the front panel (2 screws) (figure 17, page 18).
- Open the power control box.
- Make the connections in accordance with the diagram figure 38.

Do not place the sensor lines and the sector supply lines in parallel in order to avoid interferences due to voltage points in the sector supply.

Ensure that all the electrical cables are housed in the spaces provided for this purpose.

### • Interconnection between the outdoor unit and the hydraulic unit

Comply with the correspondence between the markings on the hydraulic unit's terminals and those on the outdoor unit when connecting the interconnection cables.

A connection error could cause the destruction of one or other of the units.

### • Electrical back-ups

If the heat pump is not installed with a boiler connection:

- Connect the electrical supply for the back-ups to the electrical panel.

### • Boiler connection (option)

☞ **If the boiler connection option is used, the electric boost option must not be connected.**

- Please refer to the instructions supplied with the boiler connection kit.
- Please refer to the instructions supplied with the boiler.

### • Second heating circuit

- Please refer to the instructions supplied with the second circuit kit or/and Regulation extension kit.

### • Telephone modem (Not supplied)

- Please refer to the instructions for the extension controller kit.

### • DHW tank with electrical back-up heating (option)

If the installation is fitted with a DHW tank with electrical back-up heating:

- Please refer to the instructions supplied with the DHW kit.
- Please refer to the instructions supplied with the DHW tank.

### • Contract with the power provider

The heat pump's operation can be controlled to suit special contracts (e.g. off-peak, day/night). In particular, domestic hot water (DHW) at Nominal temperature will be produced during the off-peak hours when electricity is cheaper.

- Connect the "Power Provider" contact to input EX2.
- Set the parameter (1620) to "Off-peak hours".
- 230V on input EX2 = "Peak hours" information activated.

### • Power shedding or EJP (peak day removal)

Power limitation is intended to reduce electrical consumption when this is too high compared to the contract with the power provider.

- Connect the power limiting device to input EX1, the back-ups for the heat pump and the DHW stop in the event of over-consumption by the dwelling.
- 230 V on input EX1 = power limitation in progress.

### • External faults the heat pump

- Any component of carryforward of information (Heated floor thermal safety fuse, thermostat, pressure switch, etc.) may signal an external problem and stop the heat pump.
- Connect the external component to input EX3.
- 230 V on input EX3 = stoppage of heat pump (the system displays Error 369).

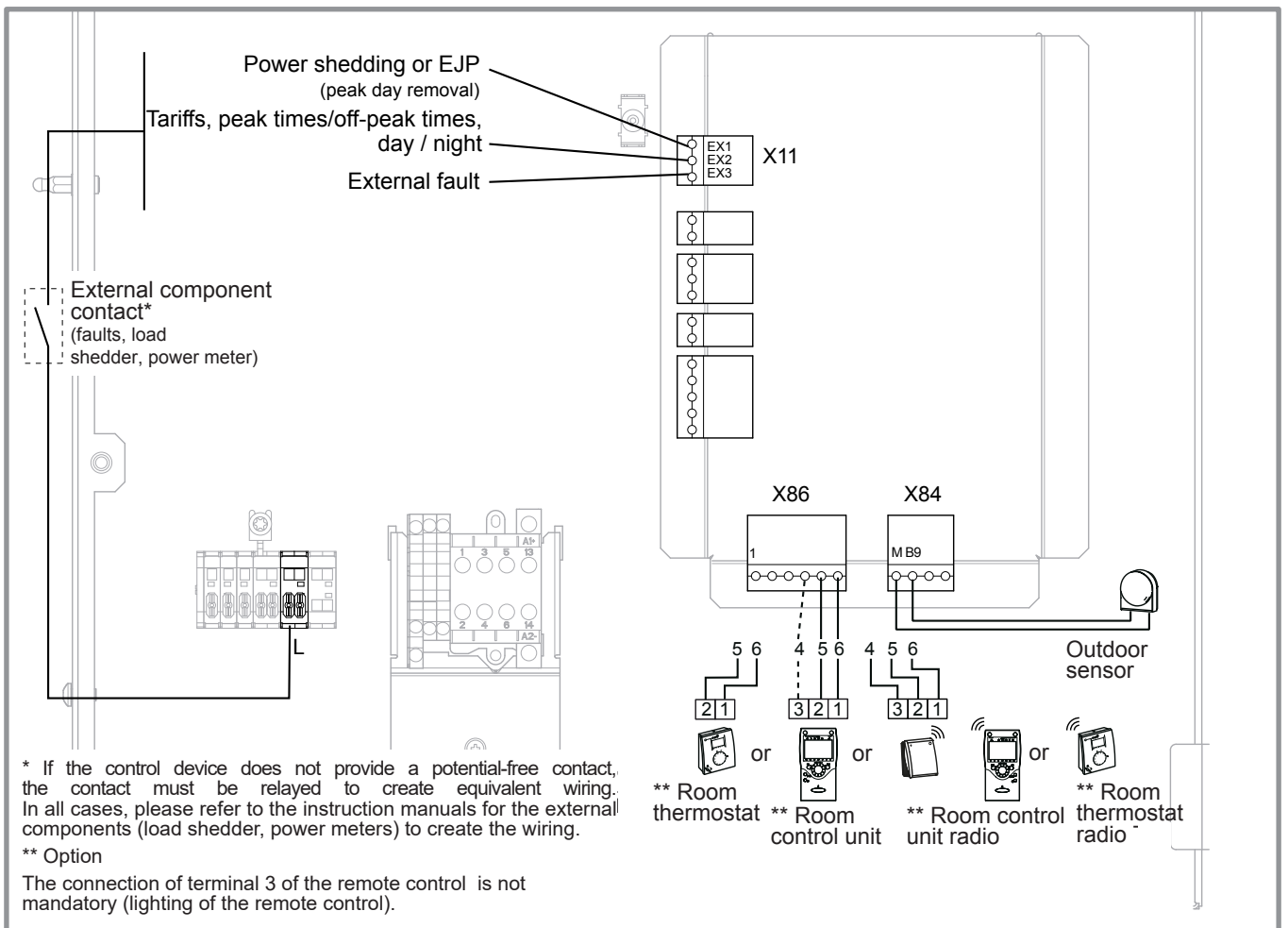


figure 36 - Connections to the heat pump regulator (accessories and options)



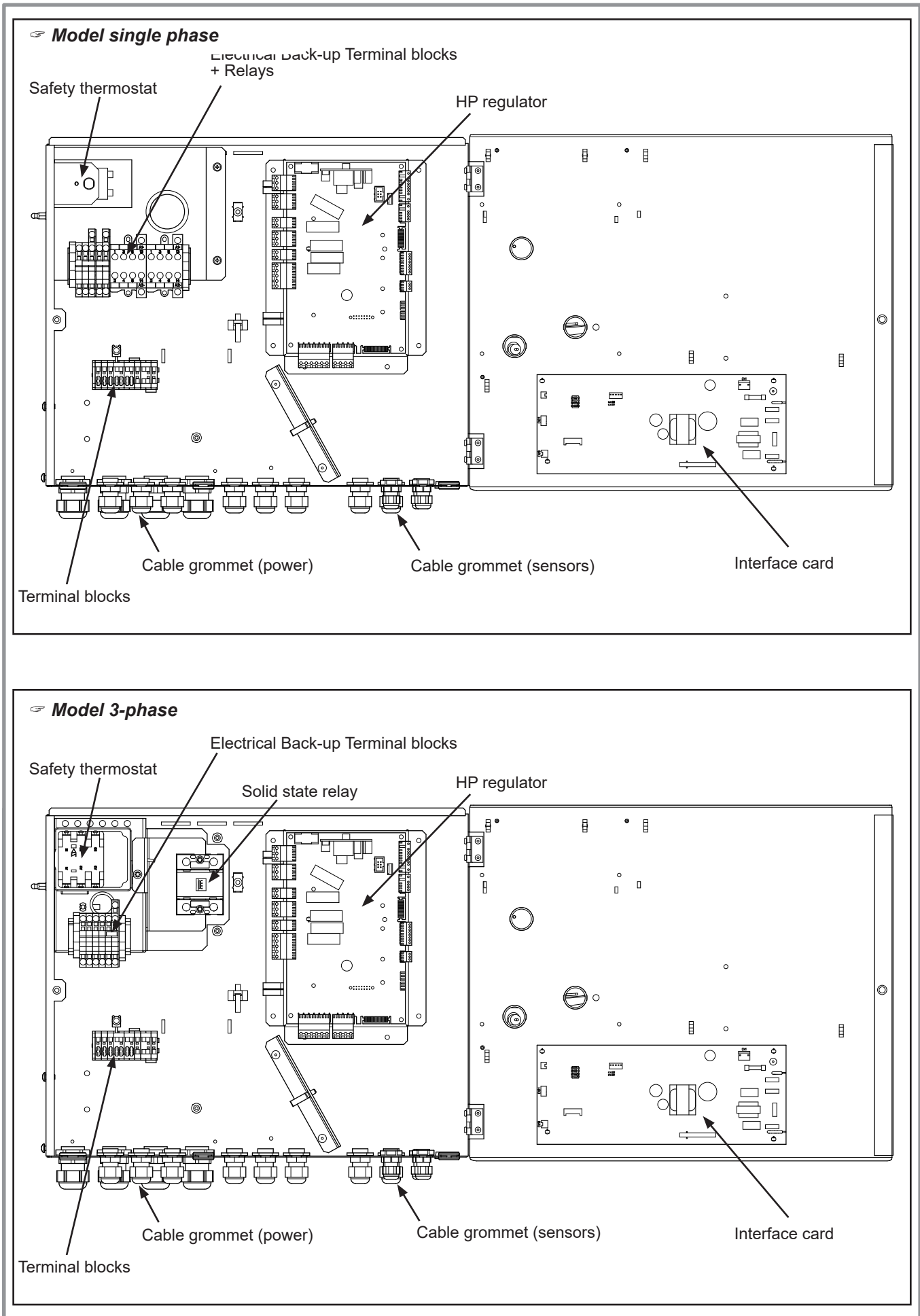


figure 37 - Access to hydraulic model electric box and description



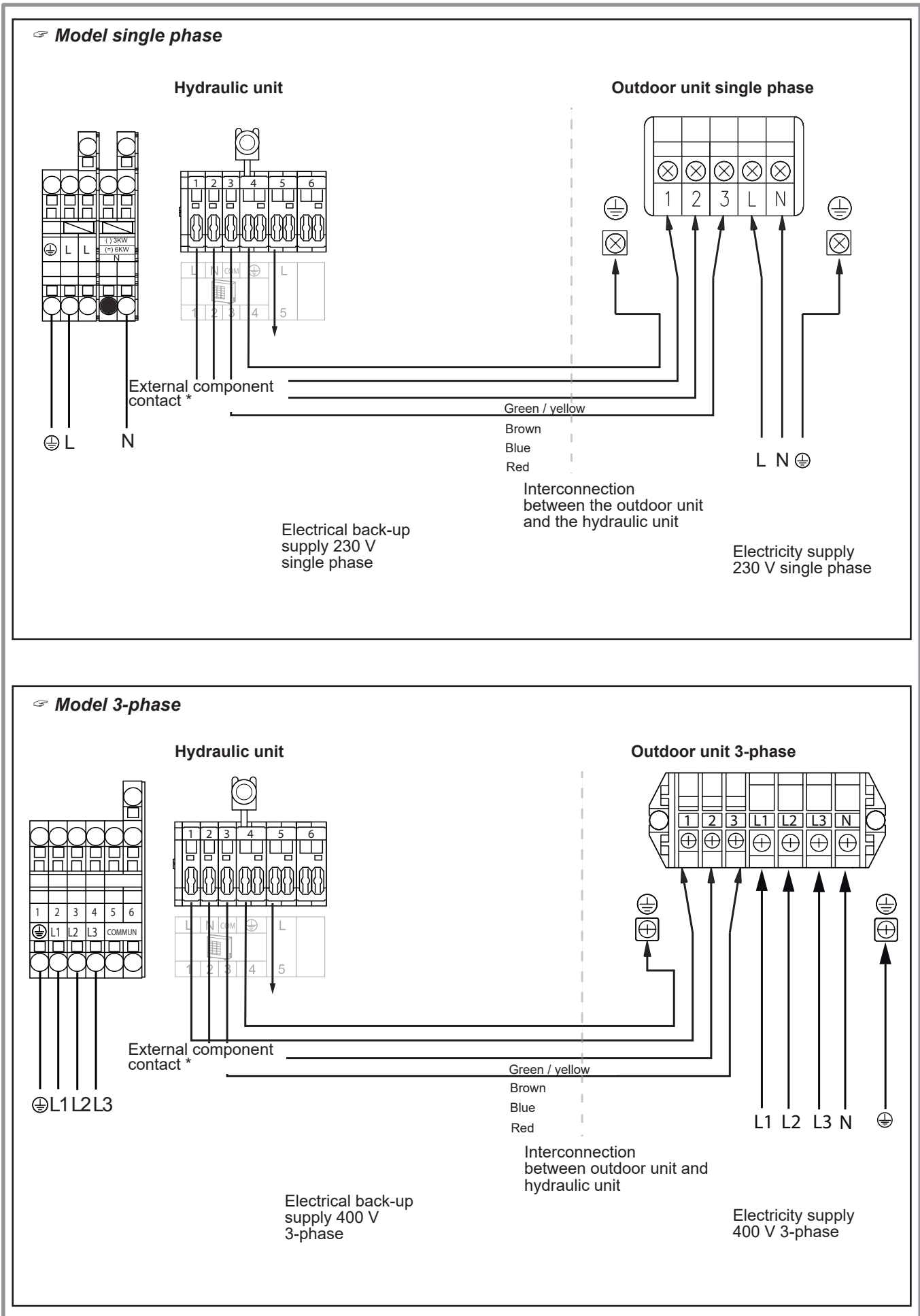


figure 38 - Connection to terminal block and power relays

## 5.6 Outdoor sensor

The outdoor sensor is required for the heat pump to operate correctly.

Consult the fitting instructions on the packaging.

Place the sensor on the coldest part, generally the northern or north-eastern side.

In any case, it must not be exposed to the morning sun. It must be installed so as to be easily accessible but at least 2.5 m from the floor.

It is essential that it avoid any sources of heat such as flues, the upper parts of doors and windows, proximity to extraction vents, the underneath of balconies and under-eave areas, which would isolate the sensor from variations in the outdoor air temperature.

- Connect the outdoor sensor to the connector **X84** (terminals **M** and **B9**) on the heat pump control board.

## 5.7 Room thermostat and/or room control unit

The room thermostat (room control unit) is optional.

Consult the fitting instructions on the packaging.

The sensor must be installed in the living room area on a very uncluttered wall. It must be installed so as to be easily accessible.

Avoid direct sources of heat (chimney/flue, television, cooking hobs), draughty areas (ventilation, door, etc.).

Air leaks in the seals in the constructions are often translated into cold air blowing through the electrical conduits. Lag the electrical conduits if there is a cold draught on the back of the IR sensor.

### 5.7.1 Installing a room sensor

#### • Room thermostat

- Connect the room thermostat to the **X86** connector of the heat pump's regulator board using the connector provided (terminals **1**, **2**).

#### • Wireless room thermostat

- Please refer to the instructions .

### 5.7.2 Installing a room control unit

#### • Remote control unit

- Connect the remote control to the **X86** connector of the heat pump's regulator board using the connector provided (terminals **1**, **2** and **3**).

#### • Wireless remote control

- Please refer to the instructions .

### 5.7.3 Fan convectors or dynamic radiators area

If the installation is equipped with fan convector or dynamic radiators, **Do not use a room sensor in the area.**

## 6 Commissioning

- Close the installation's main circuit breaker.

On first commissioning (or in winter), in order to allow the compressor to pre-heat, engage the installation's main circuit breaker (power supply to the outdoor unit) some hours before starting up the tests.

- Engage the start/stop switch.

To ensure that inputs EX1, EX2 and EX3 operate correctly: Check that the live-neutral polarity of the electrical supply is correct.



When the power is switched on and every time that the ON/OFF button is switched off and then switched on again, the outdoor unit will take approximately 4 minutes to start up, even if the setting is requesting heating.

The display can show error 370 when the appliance (re)starts. Do not be concerned, the communication between the outdoor and hydraulic unit will re-establish itself in a few moments.

During the regulator initialisation phase, the display shows all the symbols and then "Data, update" and then "State heat pump".

- Make all the specific adjustments to the setting. (Installation configuration):

- Press .

- Hold down the key  for 3s and select the level of access used with the aid of the knob .

- Confirm with the key .

- Parameter the heat pump's setting (Consult the settings' list [page 45](#)).

On commissioning (or the case of error 10), the electrical back-up heaters are liable to start up even if the outdoor temperature at the time is above the heaters' trigger temperature.

The regulating system uses an average initial outdoor temperature of 0°C and requires some time to update this temperature.

To avoid this situation, the sensor must be connected correctly. Re-initialise parameter 8703 (commissioning level, consumer diagnostic menu).

## 6.1 Configuring room thermostat (wireless)

To configure the room thermostat and connect it to the appropriate heating zone:

- Hold down the presence key for more than 3 seconds. The room thermostat displays RU and a number flashes.
- Turn the wheel to choose the zone (1, 2).
- **If the installation is fitted with 2 room thermostats,**
- **First connect one room thermostat and configure it in zone 2,**
- **Then connect the other room thermostat and configure it as default in zone 1.**

- Hold down the presence key; the room thermostat displays P1 and a flashing number.
  - 1: Automatic recording: a correction of the setting with the button is adopted without any particular confirmation (timeout) or by pressing the mode key.
  - 2: Recording with confirmation: a correction of the setting with the button is not adopted until the mode key is pressed.

- Press the presence key again; the room thermostat displays P2 and a flashing number.

0: OFF: all the operating elements are engaged.


1: ON: the following operating elements are locked:

- Switching over the heating circuit's operating mode,
- Adjusting the comfort setting,
- Changing the operating level.

The room thermostat displays OFF for 3 seconds when a locked button is pressed.

## 6.2 Configuring room control unit (wireless)

During commissioning, after an initialisation period of approx. 3 minutes, the user's language must be set:

- Press .
- Choose menu "Operator section".
- Choose language.
- Select the language (**English**, Deutsch, Français, Italiano, Nederlands, Español, Português, Dansk...).

 **In the case of 2 heating circuits,**

- Choose the allocation of the room control unit (room appliance 1 or 2...) line **40\***.
- According to the allocation selected check and, if necessary, modify the settings for lines **42\***, **44\***, **48\***

Line	Function	Setting range or display	Setting increment	Basic setting
40	I Use as...	Room appliance 1, 2, P, User interface 1, 2, P, Service appliance		Room appliance 1
	This line regulates the use of the room control unit. Depending on how it is used, other settings will be necessary (lines 42, 44, 48).			
42	I Appliance allocation 1	Heating circuit 1, Heating circuit 1 & 2, Heating circuit 1 & P, All the heating circuits		Heating circuit 1
44	I Operation HC2 (command HC2)	Commonly with HC1, Independent		Commonly with HC1
	This function enables you to choose whether you wish the room thermostat (as an option) to act on both zones or just a single zone.			
48	I Occupancy control switch function	Without, Heating circuit 1, Heating circuit 2, Common		

\* **These parameter lines are only accessible from the room control unit.**

# 7 Regulation system

## 7.1 User interface, Room control unit (option) and Room thermostat (option)

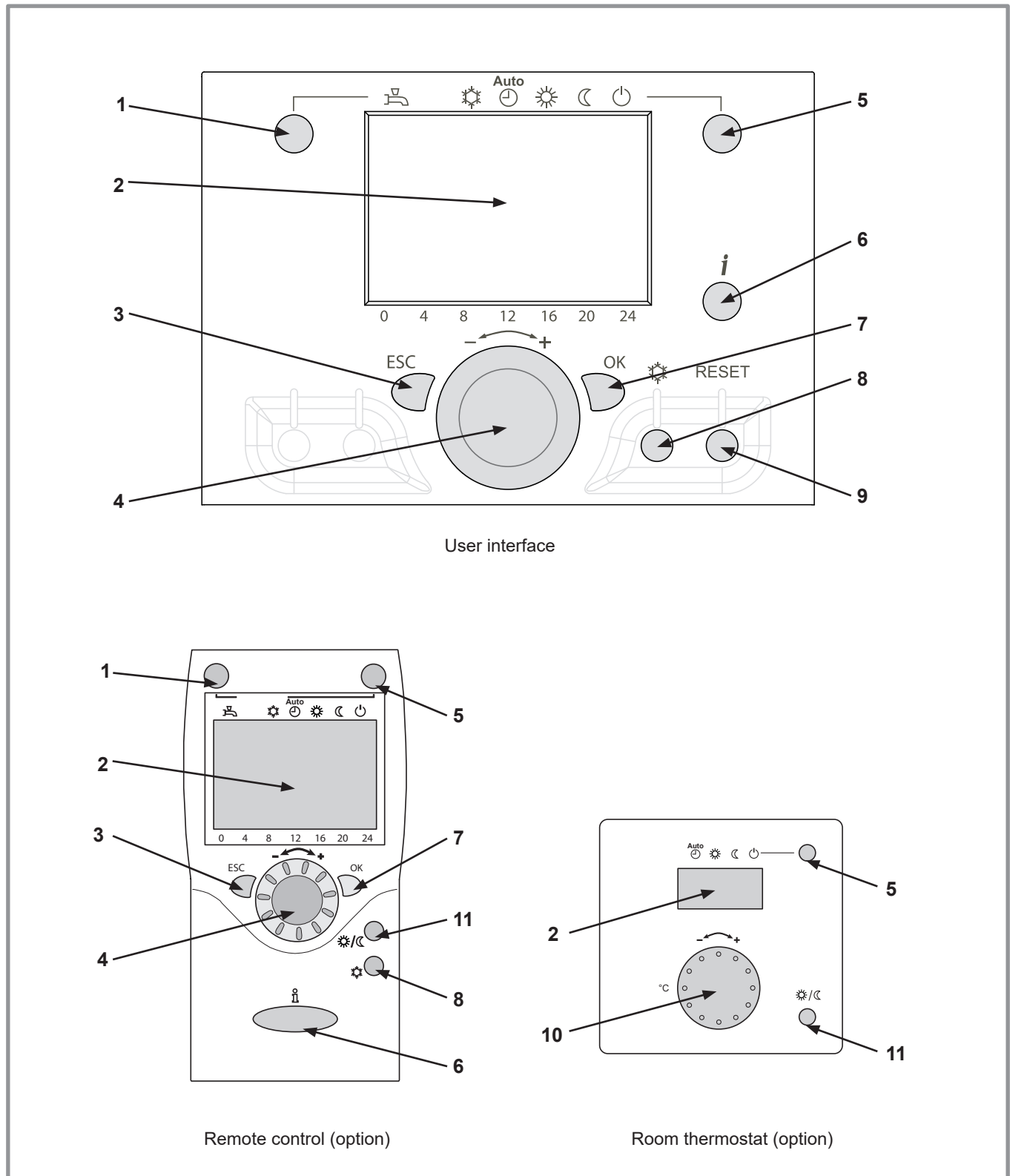












figure 39 - User interface, Room control unit (option) and Room thermostat (option)

Ref.	Function	- Definitions
1	Selecting of the DHW operating mode (Domestic hot water)	If the installation is fitted with a DHW tank.
	 On	- <b>On</b> : Production of DHW according to the time program.
	 Off	- <b>Off</b> : Preparing the domestic hot water for stopping with the anti-frost function active.
		- <b>Manual start button</b> : Hold down the DHW key for 3 seconds. Switch from "reduced" to "comfort" until the next time the ECS timer switches over.
2	Digital display	- Operating control. Readout of the current temperature, of the heating mode and of any faults  . - View the settings.
3	Exit "ESC"	- Quit the menu.
4	Navigation and setting	- Selecting the menu. - Setting parameters. - Adjusting the ambient temperature setpoint.
5	Selecting the heating mode	-  Heating operating according to the heating programme (Summer/winter mode switchover is automatic). -  Constant comfort temperature. -  Constant reduced temperature. -  Stand-by mode with anti-frost protection (Provided that the heat pump's electrical power supply is not interrupted).
6	Information display	- Various data (please see <a href="#">page 69</a> ). -  Reading error code (please see <a href="#">page 66</a> ). -  Information concerning maintenance, special mode.
7	Confirm "OK"	- Input into the selected menu. - Confirmation of the parameter settings. - Confirmation of the adjustment to the comfort temp. setting.
8	Selecting cooling mode	If the installation is fitted with the cooling kit: -  Cooling operating according to the heating programme (Summer/winter mode switchover is automatic).
9	RESET button (Brief press)	- Reinitialising the parameters and cancelling error messages. <b>Do not use during normal operation.</b>
10	Control knob	- Adjusting the ambient temperature setpoint.
11	Presence key	- Comfort / Reduced switchover.

## 7.2 Description of the display

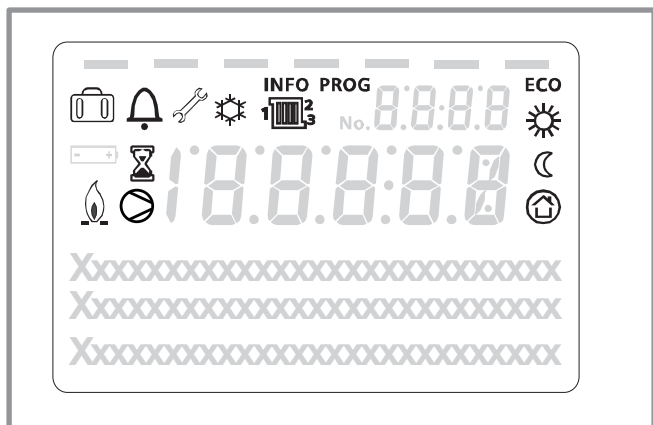


figure 40 - User interface display

Symbols	Definitions
	- Heating mode active with reference to the heating circuit.
	- Heating in comfort mode.
	- Heating in reduced mode.
	- Heating in "standby" mode (freeze protection).
	- Cooling mode active.
	- Holiday mode activated.
	- Process in progress.
	- Compressor operation.
	- Burner operation.
	- Default message.
	- Service / Special operation.
<b>INFO</b>	- Information level activated.
<b>PROG</b>	- Programme activated.
<b>ECO</b>	- ECO mode activated (Heating temporarily stopped).
	- Hour / Parameter number / Setpoint value.
	- Room temperature / Setpoint value.
	- Setpoint information / Parameter Information.

## 7.4 Temperature control

The heat pump's operation is subject to the temperature control.

The set temperature for the water in the heating circuit is adjusted according to the outdoor temperature.

If there are thermostatic valves on the installation, these must be fully open or adjusted for higher than the normal set temperature.

### 7.4.1 Set to

During installation, the temperature control must be parametered according to the heat emitters and the dwelling's insulation.

The temperature control' curves (figure 42) refer to an ambient setting of 20°C.

The slope of the temperature control (parameter 720) determines the impact of the variations in the outdoor temperature on the initial heating temperature variations.

The higher the slope, the more a slight reduction in the outdoor temperature causes a significant increase in the flow water temperature in the heating circuit.

The off-set in the temperature control (parameter 721) modifies the initial temperature of all the curves, without modification of the slope (figure 43).

The corrective actions in the case of any inconvenience are detailed in the table (figure 44).

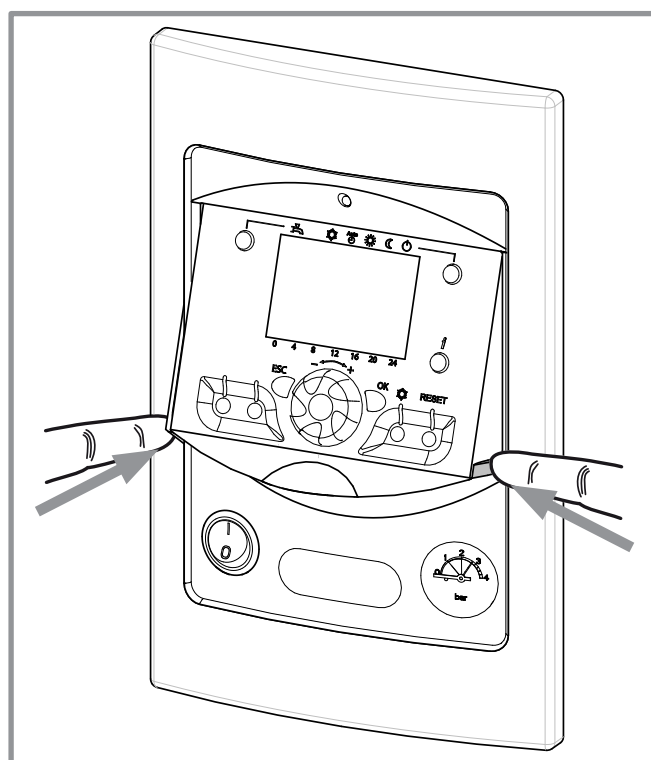


figure 41 - Closing the display

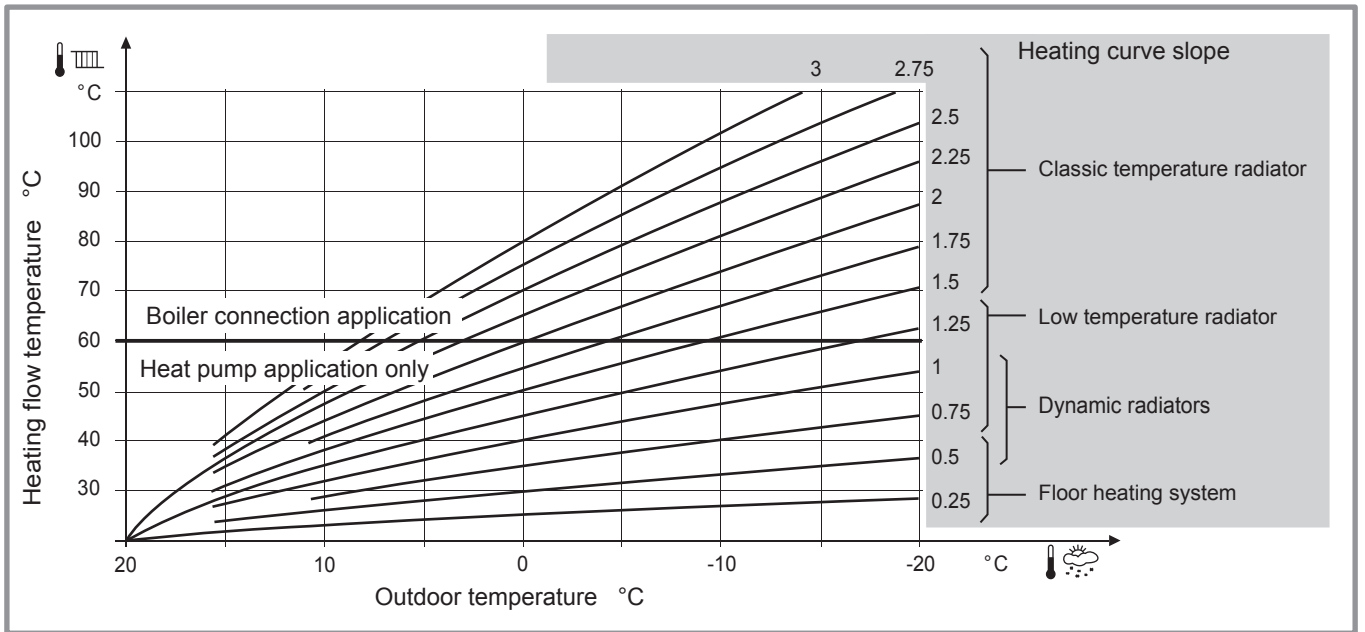


figure 42 - Heating curve slope (line 720)

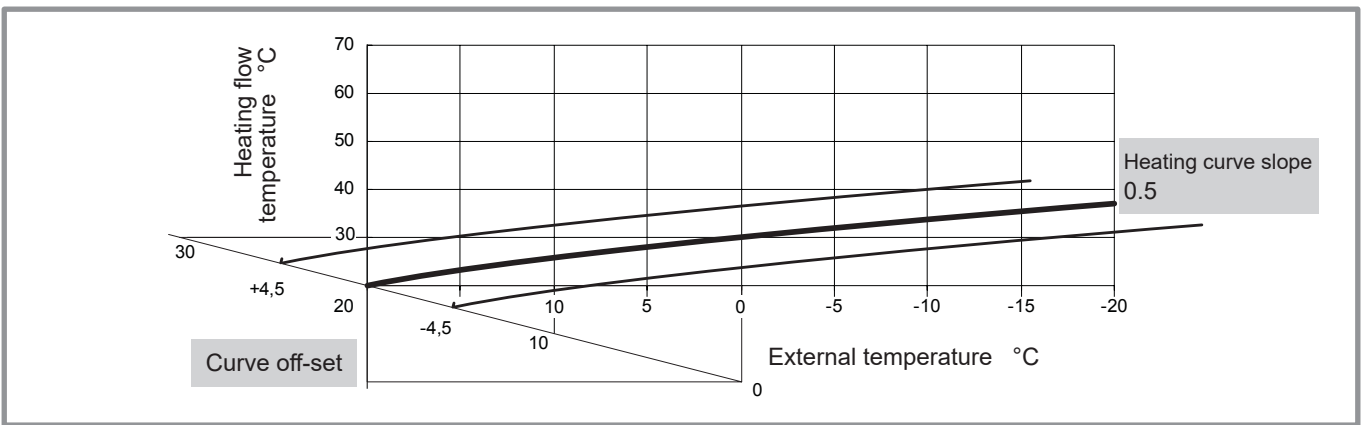


figure 43 - Off-set of the heating curve (line 721)

Sensations...		Corrective actions on the temperature control:	
...in mild weather	...in cold weather	Curve slope (line 720)	Curve off-set (line 721)
OK	&  OK	→ No correction	No correction
Cold	&  Hot	→	
Cold	&  OK	→	
Cold	&  Cold	→ No correction	
OK	&  Hot	→	No correction
OK	&  Cold	→	No correction
Hot	&  Hot	→ No correction	
Hot	&  OK	→	
Hot	&  Cold	→	

figure 44 - Corrective actions in the case of discomfort



## 7.5 Parametering the setting

### 7.5.1 General

Only the parameters accessible to levels:

- U** – End user.
- I** – Commissioning level.
- S** - Engineer level.

Are described in this document.

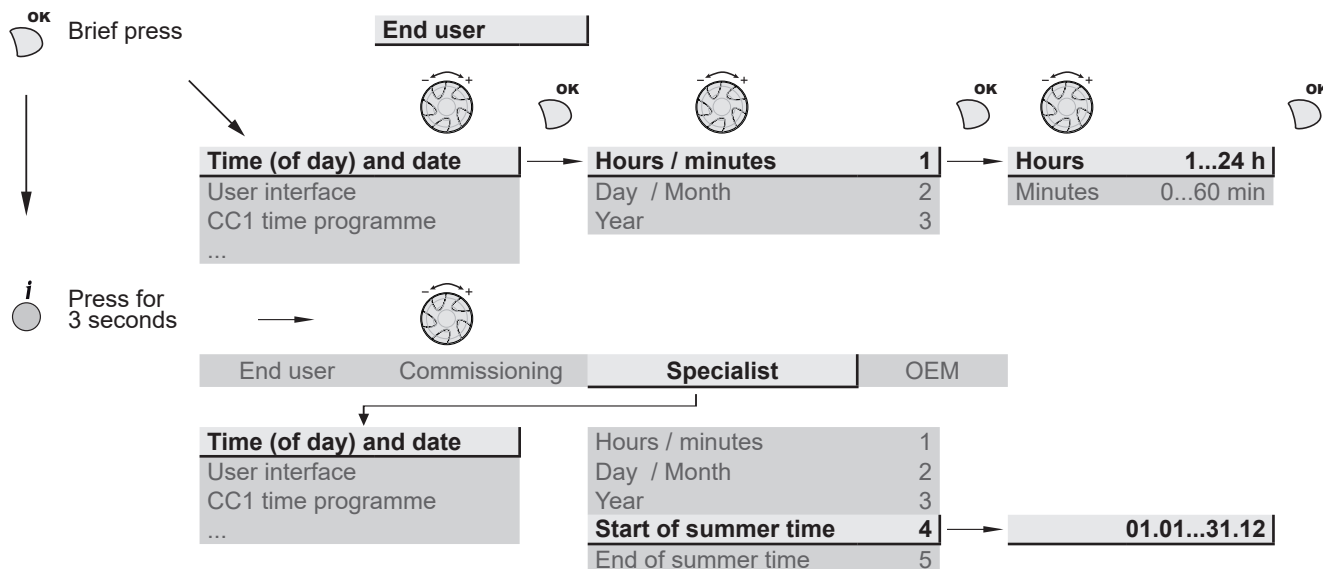
The access levels are specified in the second column of the table by means of the letters **U**, **I** and **S**.

The OEM parameters are not described and require a manufacturer's access code.

### 7.5.2 Setting parameters

- Choose the desired level.
- Scroll the menu list.
- Choose the desired menu.
- Scroll the function lines.
- Choose the desired line.
- Adjust the parameter.
- Check the setting by pressing **OK**.
- To return the menu, press **ESC**.

If no setting is made for 8 minutes, the screen returns automatically to the basic display.



### 7.5.3 Recommended settings according to the heat emitters installation

		Very Low Temperature radiators / Floor heating-cooling	Low Temperature radiators	Dynamic radiators or fan coil heaters	Classic radiators
Heating curve slope	720 (CC1)	from 0.25 to 0.5	from 0.5 to 1.25	from 0.4 to 1.1	from 1.25 to 3
	1020 (CC2)				
Heating curve displacement	721 (CC1)	0	0	4	0
	1021 (CC2)				
Flow temp setpoint mini	740 (CC1)	factory setting (17°C)	factory setting (17°C)	30 or 35°C	factory setting (17°C)
	1040 (CC2)				
Flow temp setpoint maxi	741 (CC1)	50°C	factory setting (60°C)	65°C	65°C
	1041 (CC2)				
Charging time limitation (DHW)	5030	factory setting (90 mn)	factory setting (90 mn)	40 mn	factory setting (90 mn)

### 7.5.4 List of function lines (settings, diagnosis, status)

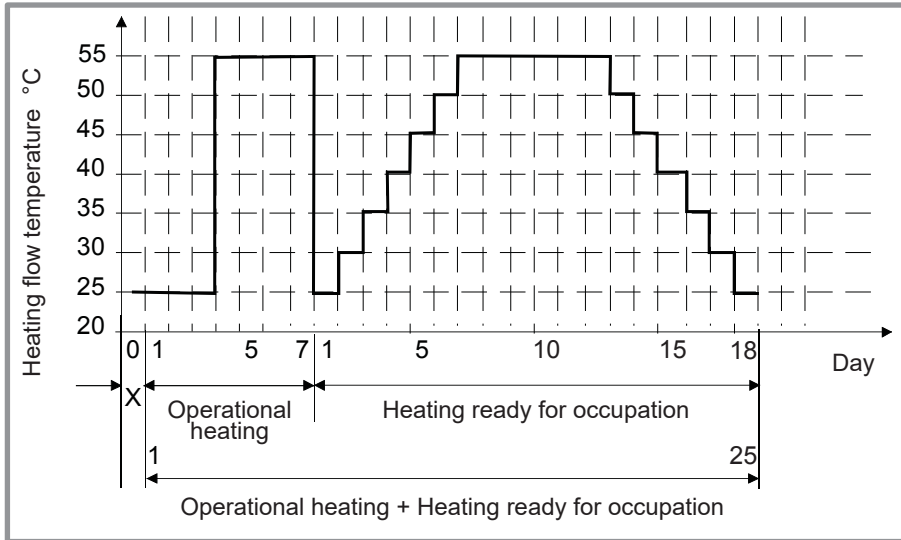
<b>Line</b>	<b>Function</b>	<b>Setting range or display</b>	<b>Setting increment</b>	<b>Basic setting</b>
<b>Time of day and date</b>				
1	<b>U</b> Hours / Minutes	00:00... 23:59	1	
2	<b>U</b> Day / Month	01.01... 31.12	1	
3	<b>U</b> Year	1900... 2099	1	
5	<b>S</b> Start of Summer time (Day / Month)	01.01... 31.12	1	<b>25.03</b>
6	<b>S</b> End of Summer time (Day / Month)	01.01... 31.12	1	<b>25.10</b>
The change of hour will appear at 3:00 first Sunday after the regulated date.				
<b>Operator Section</b>				
20	<b>U</b> Language	English, Français, Italiano, Nederlands...		<b>English</b>
22	<b>S</b> Info	Temporary, Permanent		<b>Temporary</b>
26	<b>S</b> Operation locking	On, Off		<b>Off</b>
27	<b>S</b> Programming locking	Off, On		<b>Off</b>
28	<b>I</b> Direct setting	Automatic storage, With confirmation		<b>With confirmation</b>
29	<b>I</b> Temperature units Pressure units	°C, °F bar, psi		<b>°C bar</b>
44	<b>I</b> Operation HC2	Jointly with HC1 Independently		<b>Jointly with HC1</b>
46	<b>I</b> Operation HC3/P	Jointly with HC1 Independently		<b>Jointly with HC1</b>
70	<b>S</b> Display software version			
<b>Time program heating / cooling, circuit 1</b>				
500	<b>U</b> Pre-selection (Day / Week)	Mon-Sun, Mon-Fri, Sat-Sun, Monday, Tuesday, ...		<b>Mon-Sun</b>
501	<b>U</b> 1st phase On (start)	00:00... --:--	10 min	<b>6:00</b>
502	<b>U</b> 1st phase Off (end)	00:00... --:--	10 min	<b>22:00</b>
503	<b>U</b> 2nd phase On (start)	00:00... --:--	10 min	<b>--:--</b>
504	<b>U</b> 2nd phase Off (end)	00:00... --:--	10 min	<b>--:--</b>
505	<b>U</b> 3rd phase On (start)	00:00... --:--	10 min	<b>--:--</b>
506	<b>U</b> 3rd phase Off (end)	00:00... --:--	10 min	<b>--:--</b>
516	<b>U</b> Default values, Circuit 1	No, Yes		<b>No</b>
Yes + OK: The default values memorised in the regulator replace and cancel the customised heating programs. Your customised settings are therefore lost.				

<i>Line</i>	<i>Function</i>	<i>Setting range or display</i>	<i>Setting increment</i>	<i>Basic setting</i>
<b>Time program heating / cooling, circuit 2</b>				
Only with the 2nd circuit kit option.				
520	<b>U</b> Pre-selection (Day / Week)	Mon-Sun, Mon-Fri, Sat-Sun, Monday, Tuesday, ...		<b>Mon-Sun</b>
521	<b>U</b> 1st phase On (start)	00:00... --:--	10 min	<b>6:00</b>
522	<b>U</b> 1st phase Off (end)	00:00... --:--	10 min	<b>22:00</b>
523	<b>U</b> 2nd phase On (start)	00:00... --:--	10 min	--:--
524	<b>U</b> 2nd phase Off (end)	00:00... --:--	10 min	--:--
525	<b>U</b> 3rd phase On (start)	00:00... --:--	10 min	--:--
526	<b>U</b> 3rd phase Off (end)	00:00... --:--	10 min	--:--
536	<b>U</b> Default values, Circuit 2	No, Yes		<b>No</b>
Yes + OK: The default values memorised in the regulator replace and cancel the customised heating programs. Your customised settings are therefore lost.				
<b>Time program 4 / DHW</b>				
If the installation is fitted with the DHW kit.				
560	<b>U</b> Pre-selection (Day / Week)	Mon-Sun, Mon-Fri, Sat-Sun, Monday, Tuesday, ...		<b>Mon-Sun</b>
561	<b>U</b> 1st phase On (start)	00:00... --:--	10 min	<b>00:00</b>
562	<b>U</b> 1st phase Off (end)	00:00... --:--	10 min	<b>05:00</b>
563	<b>U</b> 2nd phase On (start)	00:00... --:--	10 min	<b>14:30</b>
564	<b>U</b> 2nd phase Off (end)	00:00... --:--	10 min	<b>17:00</b>
565	<b>U</b> 3rd phase On (start)	00:00... --:--	10 min	--:--
566	<b>U</b> 3rd phase Off (end)	00:00... --:--	10 min	--:--
576	<b>U</b> Default values	No, Yes		<b>No</b>
Yes + OK: The default values memorised in the regulator replace and cancel the customised heating programs. Your customised settings are therefore lost.				
<b>Holidays, heating circuit 1</b> (For the Holiday program is active, the heating mode should be on AUTO).				
641	<b>U</b> Preselection	Period 1 to 8		<b>Period 1</b>
642	<b>U</b> Period Start (Day / Month)	01.01... 31.12	1	
643	<b>U</b> Period End (Day / Month)	01.01... 31.12	1	
648	<b>U</b> Operating level	Frost protection, Reduced		<b>Frost protection</b>
<b>Holidays, heating circuit 2</b> (For the Holiday program is active, the heating mode should be on AUTO).				
If the installation consists of 2 heating circuits (Only with the 2nd circuit kit option).				
651	<b>U</b> Preselection	Period 1 to 8		<b>Period 1</b>
652	<b>U</b> Period Start (Day / Month)	01.01... 31.12	1	
653	<b>U</b> Period End (Day / Month)	01.01... 31.12	1	
658	<b>U</b> Operating level	Frost protection, Reduced		<b>Frost protection</b>

<i>Line</i>	<i>Function</i>	<i>Setting range or display</i>	<i>Setting increment</i>	<i>Basic setting</i>
<b>Heating adjustment, circuit 1</b>				
710	<b>U</b> Comfort setpoint	Reduced setpoint... Comfort setpoint maximum	0,5 °C	<b>20 °C</b>
712	<b>U</b> Reduced setpoint	Frost protection setpoint... Comfort setpoint	0,5 °C	<b>19 °C</b>
714	<b>U</b> Frost protection setpoint	4 °C... Reduced setpoint	0,5 °C	<b>8 °C</b>
716	<b>S</b> Comfort setpoint maximum	20 °C... 35 °C	1 °C	<b>28 °C</b>
720	<b>I</b> Heating curve slope (see chapter 7.5.3, page 44 & figure 42, page 43)	0,1... 4	0,02	<b>0,5</b>
721	<b>I</b> Off-set of the heating curve (figure 43, page 43)	-4,5 °C... 4,5 °C	0,5 °C	<b>0</b>
730	<b>I</b> Summer / Winter heating limits When the average of the outdoor temperatures over the past 24 hours reaches 18°C, the regulator switches off the heating (as an economy measure). During summer mode, the display shows "Eco". This function is only active in automatic mode.	8 °C... 30 °C	0,5 °C	<b>18 °C</b>
740	<b>I</b> Flow temp setpoint min (with dynamic radiator, adjust from 30 to 35°C)	8 °C... Flow temp setpoint max	1 °C	<b>17 °C</b>
741	<b>I</b> Flow temp setpoint max Floor heating system = 50 °C / Radiators = 65 °C. <b>Important Note</b> : Maximum temperature limitation is not a safety function as required by ground heating.	Flow temp setpoint min... 70 °C	1 °C	<b>60 °C</b>
750	<b>S</b> Room influence If the installation is fitted with a room thermostat: This function enables you to choose the ambient temperature's influence on the setting. If no value is entered, the setting is made based on the temperature control. If the parameter is set at 100%, the setting is only based on the ambient temperature.	1%... 100%	1%	<b>50%</b>
760	<b>S</b> Room temperature limitation As soon as the room temperature = [Setpoint line 710 (ex. 20°C) + Room temperature limitation setpoint line 760 (ex. 0,5 °C)] > 20,5 °C => The heat pump is stopped. It restarts when the room temperature falls below the setpoint (in the example, Room temperature < 20,0 °C).	0,5... 4 °C	0,5 °C	<b>0,5 °C</b>
780	<b>S</b> Quick setback	Off, Down to reduced setpoint, Down to frost prot setpoint		<b>Off</b>
790	<b>S</b> Optimum start control max (Early start to switch to the comfort setting.)	0... 360 min	10 min	<b>180 min</b>
791	<b>S</b> Optimum stop control max (Early stop to switch from the comfort setting to the reduced setting.)	0... 360 min	10 min	<b>30 min</b>
800	<b>S</b> Reduced setpoint increase start	-30... 10 °C	1 °C	<b>--</b>
801	<b>S</b> Reduced setpoint increase end	-30... 10 °C	1 °C	<b>-5 °C</b>
830	<b>S</b> Mixer valve boost	0... 50 °C	1 °C	<b>0 °C</b>
834	<b>S</b> Actuator running time	30... 873 s	1 s	<b>240 s</b>

Line	Function	Setting range or display	Setting increment	Basic setting
850	I Floor curing function (figure 1)			Off

- Off: Early interruption of the current programme, programme inactive.
- Operational heating.
- Heating ready for occupation.
- Operational heating + ready heating.
- Ready heating + operational heating.
- Manual: Manual mode enables you to programme your own concrete slab drying time. The function ends automatically after 25 days.



☞ Please comply with the standards and instructions of the manufacturer of the building ! A good performance of this function is only possible with an installation correctly implemented (hydraulic, electricity and adjustments) ! This function can be stopped by anticipation when setting the adjustment on "Stop".

figure 1 - Diagram of the concrete slab drying programmes

851	I	Floor curing setpoint manually (if line 850 = manual)	0... 95 °C	1 °C	25 °C
This function enables you to set the custom concrete slab drying temperature. This temperature remains fixed. The concrete slab-drying programme stops automatically after running for 25 days.					
856	I	Floor curing day current	0... 32		
857	I	Floor curing day completed	0... 32		
900	S	Operating mode changeover	None, Protection mode, Reduced, Comfort, Automatic	1	Reduced
Operating mode at end of concrete slab drying period					

### Cooling circuit 1

If the installation is fitted with the cooling kit (Only with the cooling kit option).

901	U	Operating mode	Protection, Automatic, Reduced, Comfort		Protection
902	U	Comfort cooling setpoint	17... 40 °C	0,5 °C	24 °C
903	U	Reduced setpoint	5... 40°C		26 °C
908	I	Flow temp setp at OT° 25°C	6... 35 °C	0,5 °C	20 °C
909	I	Flow temp setp at OT° 35°C	6... 35 °C	0,5 °C	16 °C
912	I	Cooling limit at OT°	8... 35 °C	0,5 °C	24 °C
913	S	Lock time at end of heating / cooling	8... 100	1 h	24 h
918	S	Summer comp start at OT°	20... 50 °C	1 °C	26 °C
919	S	Summer comp end at OT°	20... 50 °C	1 °C	40 °C
920	S	Summer comp setp increase	1... 10 °C	1 °C	4 °C
923	S	Flow temp setp min OT° 25°C	6... 35 °C	0,5 °C	18 °C
924	S	Flow temp setp min OT° 35°C	6... 35 °C	0,5 °C	18 °C

Line	Function	Setting range or display	Setting increment	Basic setting
928	<b>S</b> Room influence If the installation is fitted with a room thermostat: This function enables you to choose the ambient temperature's influence on the setting. If no value is entered, the setting is made based on the temperature control. If the parameter is set at 100%, the setting is only based on the ambient temperature.	1... 100 %	1 %	<b>80 %</b>
932	<b>S</b> Room temp limitation	0,5... 4 °C	0,5 °C	<b>0,5 °C</b>
938	<b>S</b> Mixing valve decrease	0... 20 °C	1 °C	<b>0 °C</b>
941	<b>S</b> Actuator running time	30... 873 s	1 s	<b>240 s</b>
963	<b>S</b> With prim contr / system pump *Basic setting : 1 circuit = No ; 2 circuits = Yes.	No, Yes		<b>No*</b>
<b>Heating adjustment, Circuit 2</b> Only with the 2nd circuit kit option (If the installation consists of 2 heating circuits).				
1010	<b>U</b> Comfort setpoint	Reduced setpoint... Comfort setpoint maximum	0,5 °C	<b>20 °C</b>
1012	<b>U</b> Reduced setpoint	Frost protection setpoint... Comfort setpoint	0,5 °C	<b>19 °C</b>
1014	<b>U</b> Frost protection setpoint	4 °C... Reduced setpoint	0,5 °C	<b>8 °C</b>
1016	<b>S</b> Comfort setpoint maximum	Comfort temp... 35 °C	1 °C	<b>28 °C</b>
1020	<b>I</b> Heating curve slope (see chapter 7.5.3, page 44 & figure 42, page 43)	0,1... 4	0,02	<b>0,5</b>
1021	<b>I</b> Off-set of the heating curve (figure 43, page 43)	-4,5... 4,5 °C	0,5 °C	<b>0 °C</b>
1030	<b>I</b> Summer / Winter heating limits When the average of the outdoor temperatures over the past 24 hours reaches 18°C, the regulator switches off the heating (as an economy measure). During summer mode, the display shows "Eco". This function is only active in automatic mode.	8... 30 °C	0,5 °C	<b>18 °C</b>
1040	<b>I</b> Flow temp setpoint min (with dynamic radiator, adjust from 30 to 35°C)	8... 70 °C	1 °C	<b>17 °C</b>
1041	<b>I</b> Flow temp setpoint max Floor heating system = 50 °C / Radiators = 65 °C. <b>Important Note</b> : Maximum temperature limitation is not a safety function as required by ground heating.	8... 70 °C	1 °C	<b>60 °C</b>
1050	<b>S</b> Room influence If the installation is fitted with a room thermostat: This function enables you to choose the ambient temperature's influence on the setting. If no value is entered, the setting is made based on the temperature control. If the parameter is set at 100%, the setting is only based on the ambient temperature.	1 %... 100 %	1 %	<b>50 %</b>
1060	<b>S</b> Room temperature limitation As soon as the room temperature = [Setpoint line 1010 (ex. 20°C) + Room temperature limitation setpoint line 1060 (ex. 0,5 °C)] > 20,5 °C => The heat pump is stopped. It restarts when the room temperature falls below the setpoint (in the example, Room temperature < 20,0 °C).	0,5... 4 °C	0,5 °C	<b>0,5 °C</b>
1080	<b>S</b> Quick setback	Off, Down to reduced setpoint, Down to frost prot setpoint		<b>Off</b>
1090	<b>S</b> Optimum start control max	0... 360 min	10 min	<b>180 min</b>
1091	<b>S</b> Optimum stop control max	0... 360 min	10 min	<b>30 min</b>
1100	<b>S</b> Reduced setpoint increase start	-30... 10 °C, --°C	1 °C	<b>--</b>
1101	<b>S</b> Reduced setpoint increase end	-30... 10 °C, --°C	1 °C	<b>-5 °C</b>
1130	<b>S</b> Mixer valve increase	0... 50 °C	1 °C	<b>0 °C</b>
1134	<b>S</b> Actuator running time	30... 873 s	1 s	<b>240 s</b>

<b>Line</b>	<b>Function</b>	<b>Setting range or display</b>	<b>Setting increment</b>	<b>Basic setting</b>
1150	I Floor curing function (figure 1, page 48)			<b>Off</b>
	<ul style="list-style-type: none"> <li>- Off: Early interruption of the current programme, programme inactive.</li> <li>- Operational heating.</li> <li>- Heating ready for occupation.</li> <li>- Operational heating + ready heating.</li> <li>- Ready heating + operational heating.</li> <li>- Manual: Manual mode enables you to programme your own concrete slab drying time. The function ends automatically after 25 days.</li> </ul>			
1151	I Floor curing setpoint manually (if line 1150 = manual)	0... 95 °C	1 °C	<b>25 °C</b>
	This function enables you to set the custom concrete slab drying temperature. This temperature remains fixed. The concrete slab-drying program stops automatically after running for 25 days.			
1156	I Floor curing day current	0... 32		
1157	I Floor curing day completed	0... 32		<b>0</b>
1200	S Operating mode changeover	None, Protection mode, Reduced, Comfort, Automatic		<b>Reduced</b>
	Operating mode at end of concrete slab drying period.			
<b>Cooling circuit 2</b>				
	If the installation is fitted with the cooling kit (Only with the cooling kit option).			
1201	U Operating mode	Protection, Automatic, Reduced, Comfort		<b>Protection</b>
1202	U Comfort cooling setpoint	17... 40 °C	0,5 °C	<b>24 °C</b>
1203	U Reduced setpoint	5... 40°C		<b>26 °C</b>
1208	I Flow temp setp at OT° 25°C	6... 35 °C	0,5 °C	<b>20 °C</b>
1209	I Flow temp setp at OT° 35°C	6... 35 °C	0,5 °C	<b>16 °C</b>
1212	I Cooling limit at OT°	8... 35 °C	0,5 °C	<b>24 °C</b>
1213	S Lock time at end of heating / cooling	8... 100	1 h	<b>24 h</b>
1218	S Summer comp start at OT°	20... 50 °C	1 °C	<b>26 °C</b>
1219	S Summer comp end at OT°	20... 50 °C	1 °C	<b>40 °C</b>
1220	S Summer comp setp increase	1... 10 °C	1 °C	<b>4 °C</b>
1223	S Flow temp setp min OT° 25°C	6... 35 °C	0,5 °C	<b>18 °C</b>
1224	S Flow temp setp min OT° 35°C	6... 35 °C	0,5 °C	<b>18 °C</b>
1228	S Room influence	1... 100 %	1 %	<b>80 %</b>
	If the installation is fitted with a room thermostat: This function enables you to choose the ambient temperature's influence on the setting. If no value is entered, the setting is made based on the temperature control. If the parameter is set at 100%, the setting is only based on the ambient temperature.			
1232	S Room temp limitation	0,5... 4 °C	0,5 °C	<b>0,5 °C</b>
1238	S Mixing valve decrease	0... 20 °C	1 °C	<b>0 °C</b>
1241	S Actuator running time	30... 873 s	1 s	<b>240 s</b>
1263	S With prim contr / system pump	No, Yes		<b>No*</b>

\*Basic setting : 1 circuit = No ; 2 circuits = Yes.



<i>Line</i>	<i>Function</i>	<i>Setting range or display</i>	<i>Setting increment</i>	<i>Basic setting</i>
<b>Domestic hot water</b>				
1600	<b>U</b> Operating mode	Off, On, Eco		<b>On</b>
1610	<b>U</b> Nominal setpoint	Reduced setpoint (line 1612)... 65 °C	1	<b>60 °C</b>
The backup electrical system is required to reach this level.				
1612	<b>U</b> Reduced setting	8 °C... Nominal setting (line 1610)	1	<b>40 °C</b>
1620	<b>I</b> Release of DHW load	24h / day Heating circuit time programme Programme 4 / DHW Off-peak tariff (Off-peak) Programme 4 / DHW and Off-peak		<b>Programme 4 / DHW</b>
<b>24h / day:</b> The temperature of the DHW is constantly maintained at the DHW comfort setting.				
<b>Heating circuit time programme:</b> The DHW is produced according to the programming for the ambient temperature (with 1 hour in advance when switched on).				
<b>Programme 4 / DHW:</b> The DHW programme is separate form the heating circuit programme.				
<b>Off-peak tariff* :</b> The electrical backup heating is only authorised to operate during the off-peak period.				
<b>T'prog 4/DHW or low-tariff* :</b> The electrical backup heating is authorised to operate during the comfort period or off peak.				
* - Connect the "Power Provider" contact to input EX2 (see <a href="#">figure 36, page 35</a> ). In the case of a day /night contract, the electric back-ups for the DHW tank are subject to the power supplier's tariffs. Switching on the electric back-up for the DHW tank is only authorised during off-peak hours.				
1640	<b>I</b> Legionella function	Off, Periodically (depending line setting 1641), Fixed weekday (depending line setting 1642)		<b>Off</b>
1641	<b>I</b> Legionella function periodically	1 to 7	1 day	<b>7</b>
1642	<b>S</b> Legionella function weekday	Monday, Tuesday,...		<b>Saturday</b>
1644	<b>S</b> Legionella funct time			
1645	<b>S</b> Legionella funct setpoint			
1646	<b>S</b> Legionella funct duration			
1647	<b>S</b> Legionella funct circ pump	Arrêt, Marche		<b>Arrêt</b>
1660	<b>S</b> Circulating pump release	Time program 3/HCP, DHW release, Time program 4/DHW, Time program 5		<b>DHW release</b>
<b>Swimming pool (Only with swimming pool kit option)</b>				
2055	<b>U</b> Setpoint solar heating	8... 80 °C		<b>26 °C</b>
2056	<b>U</b> Setpoint source heating	8... 35 °C		<b>22 °C</b>
2057	<b>S</b> Swi diff source heating	0,5... 3 °C		<b>0,5 °C</b>
2065	<b>S</b> Charging priority solar	Priority 1, Priority 2, Priority 3		<b>Priority 1</b>
2080	<b>S</b> With solar integration	No, Yes		<b>Yes</b>

Line	Function	Setting range or display	Setting increment	Basic setting
<b>Heat pump (HP)</b>				
2803	S Overrun time cond pump	8... 240 s	1 s	<b>240s</b>
2843	S Compressor off time min	0... 120 min	1 min	<b>8 min</b>
2844	S Switch-off temp max	8... 100 °C	1 °C	<b>75 °C</b>
2862	S Locking time stage 2 / mod	0... 40 min	1 min	<b>5 min</b>
2873	S Compressor mod run time	10... 600 s	1 s	<b>240 s</b>
2882	S Release integr electric flow	0... 500 °Cmin	1 °Cmin	<b>100 °Cmin</b>
2884	S Release el flow below OT Electrical release - start-up with outdoor temperature	-30... 30 °C		<b>2 °C</b>
2916	S Max setpoint HP DHW charg	8... 80 °C		<b>60 °C</b>
2920	S With electrical utility lock (EX1)	Locked (Blocked on standby), Released		<b>Released</b>
<b>Released</b> : HP = ON _ Back-up DHW = off _ 1st back-up HP = off _ 2nd back-up HP = off _ Boiler = ON <b>Locked (Blocked on standby)</b> : HP = off _ Back-up DHW = off _ 1st back-up HP = off _ 2nd back-up HP = off _ Boiler = ON				
<b>Energy meter</b>				
3095 --> 3110 : Not used				
3113	U Energy brought in		Kwh	--
<b>Cumulation of total consumed electrical energy.</b> Electrical energy consumed = Electrical energy absorbed by outdoor unit + electric energy absorbed by the heating electrical backup and / or DHW electrical backup (if installed).				
3121 --> 3123 : Not used				
3124	U Energy brought in heating 1 (N - 1)		Kwh	--
3125	U Energy brought in DHW 1		Kwh	--
3126	U Energy brought in cooling 1		Kwh	--
3128 --> 3130 : Not used				
3131	U Energy brought in heating 2 (N - 2)		Kwh	--
3132	U Energy brought in DHW 2		Kwh	--
3133	U Energy brought in cooling 2		Kwh	--
3135 --> 3137 : Not used				
3138	U Energy brought in heating 3 (N - 3)		Kwh	--
3139	U Energy brought in DHW 3		Kwh	--
3140	U Energy brought in cooling 3		Kwh	--
3142 --> 3144 : Not used				
3145	U Energy brought in heating 4 (N - 4)		Kwh	--
3146	U Energy brought in DHW 4		Kwh	--
3147	U Energy brought in cooling 4		Kwh	--
3149 --> 3151 : Not used				
3152	U Energy brought in heating 5 (N - 5)		Kwh	--
3153	U Energy brought in DHW 5		Kwh	--
3154	U Energy brought in cooling 5		Kwh	--

**Note: "Energy" Counters increment as of 1 July each year.**

<b>Line</b>	<b>Function</b>	<b>Setting range or display</b>	<b>Setting increment</b>	<b>Basic setting</b>
3156 --> 3158 : Not used				
3159	<b>U</b> Energy brought in heating 6 (N - 6)		Kwh	--
3160	<b>U</b> Energy brought in DHW 6		Kwh	--
3161	<b>U</b> Energy brought in cooling 6		Kwh	--
3163 --> 3165 : Not used				
3166	<b>U</b> Energy brought in heating 7 (N - 7)		Kwh	--
3167	<b>U</b> Energy brought in DHW 7		Kwh	--
3168	<b>U</b> Energy brought in cooling 7		Kwh	--
3170 --> 3172 : Not used				
3173	<b>U</b> Energy brought in heating 8 (N - 8)		Kwh	--
3174	<b>U</b> Energy brought in DHW 8		Kwh	--
3175	<b>U</b> Energy brought in cooling 8		Kwh	--
3177 --> 3179 : Not used				
3180	<b>U</b> Energy brought in heating 9 (N - 9)		Kwh	--
3181	<b>U</b> Energy brought in DHW 9		Kwh	--
3182	<b>U</b> Energy brought in cooling 9		Kwh	--
3184 --> 3186 : Not used				
3187	<b>U</b> Energy brought in heating 10 (N - 10)		Kwh	--
3188	<b>U</b> Energy brought in DHW 10		Kwh	--
3189	<b>U</b> Energy brought in cooling 10		Kwh	--
3190	<b>S</b> Reset fixed day storage	No, Yes		<b>No</b>
<b>Reset the historical counters (1 to 10). The general counter (parameter 3113) is not reset.</b>				
3197	<b>S</b> Compressor electrical power	0,1...60	0,1	<b>See table below</b>

**Set the parameter 3197 according to the outdoor unit**

Heat Pump	Outdoor unit	Parameter 3197
High Power 112 Single phase	WOYG112LHT WOYG112LCTA	4.32
High Power 140 Single phase	WOYG140LCTA	5.08
High Power 112 3-phase	WOYK112LCTA	4.28
High Power 140 3-phase	WOYK140LCTA	5.13
High Power 160 3-phase	WOYK160LCTA	5.40

3264 --&gt; 3267 : Not used

Line	Function	Setting range or display	Setting increment	Basic setting
<b>Additional generator (Boiler connection)</b>				
3692	S With DHW charging	Locked, Substitute, Complement, Instantly		<b>Substitute</b>
	<p>- <b>DHW Instantly</b> : When DHW request, the HP and the boiler are put into operation. The HP will stop when the primary return temperature is over 55 °C.</p> <p>- <b>DHW Substitute</b> : If the outdoor temperature is above 2 °C, the operation of the HP when DHW request last 5 minutes at least. The HP operating time can be extended depending on the outdoor temperature. The boiler will activate then.</p>			
3700	S Release below outdoor temperature	-50... 50 °C	1 °C	<b>2 °C</b>
3701	S Release above outdoor temperature	-50... 50 °C	1 °C	--
3705	S Overrun time	0... 120 min	1 min	<b>20 min</b>
3720	S Switching integral (for boiler relief)	0... 500 °Cmin	1 °Cmin	<b>100 °Cmin</b>
3723	S Locking time	1... 120 min	1 min	<b>30 min</b>
<b>Domestic hot water (DHW)</b>				
	If the installation is fitted with the DHW kit.			
5024	S Switching diff	0... 20 °C	1 °C	<b>7 °C</b>
5030	S Charging time limitation	10... 600 min	10 min	<b>90 min</b>
	(with dynamic radiator, adjust 40 min)			
5055	S Recooling temp	10... 95 °C	1 °C	<b>65 °C</b>
5057	S Recooling collector	Off, Summer, Always		<b>Summer</b>
5061	S Electric immersion heater release	24h / day, Release of DHW, Programme 4 / DHW		<b>Release of DHW</b>
5093	S With solar integration	No, Yes		<b>Yes</b>
<b>Installation configuration</b>				
<b>5700</b>	I Pre-setting	1,2,3,... 9	1	<b>1</b>
	<p>This control enables you to choose one of the 4 pre-selected installation configurations. The hydraulic layouts for the various configurations are detailed in the section: "Installation Configurations".</p> <ul style="list-style-type: none"> <li>- Pre-setting 1: 1 heating circuit with or without electrical back-up, with DHW tank.</li> <li>- Pre-setting 2: 2 heating circuits with or without electrical back-up, with DHW tank.</li> <li>- Pre-setting 3: Boiler connection and 1 heating circuit and DHW tank.</li> <li>- Pre-setting 4: Boiler connection and 2 heating circuits and DHW tank.</li> <li>- Pre-setting 5 and more: Not used.</li> </ul>			
5710	S Heating circuit 1	Off, On		<b>On</b>
5711	S Cooling circuit 1	Off, System with 4 tubes, System with 2 tubes		<b>Off</b>
	Set the parameter to " <b>2-pipe system cooling</b> " with the cooling kit.			
5715	S Heating circuit 2	Off, On		<b>On</b>
5716	S Cooling circuit 2	Off, 4-pipe system cooling, 2-pipe system cooling		<b>Off</b>
	Set the parameter to " <b>2-pipe system cooling</b> " with the cooling kit. If the installation consists of 2 heating circuits.			
5731	S DHW controlling element Q3	No charging request, Charging pump, Diverting valve		<b>Diverting valve</b>
5740	S Output el imm heater K6	0,1... 99 kW		<b>2</b>
	<b>5740 = Value of the DHW electrical backup - kW</b>			
5806	I Type el imm heater flow	1 : 3-stage, 2 : 2-stage excluding, 3 : 2-stage complementary, 4 : Modulating UX		<b>3 : 2-stage complementary</b>
5811	S Output el imm heater K25	0,1-...99		<b>3</b>
	<b>Without electrical backup = 0 ; Single phase electrical backup (Factory setting) = 3 ; 3-phase electrical backup = 9</b>			

Line	Function	Setting range or display	Setting increment	Basic setting
5813	S Output el imm heater K26	0,1-...99		3
<b>Without electrical backup = 0 ; Single phase electrical backup 3 kW = 0 ; Single phase electrical backup 6 kW (Factory setting) = 3 ; 3-phase electrical backup = 0</b>				
5950	S Function input H1 (Connector X86, terminals B1 & M)			None
0: None, 1: Op'mode change zones+DHW, 2: Optg mode changeover DHW, 3: Op'mode changeover zones, 4: Op'mode changeover zone 1, 5: Op'mode changeover zone 2, 6: Op'mode changeover zone 3, 8: Error/alarm message, 9: Consumer request VK1, 10: Consumer request VK2, 11: Release swi pool source heat, 13: Release swi pool solar, 14: Operating level DHW, 15: Operating level HC1, 16: Operating level HC2, 17: Operating level HC3, 18: Room thermostat HC1, 19: Room thermostat HC2, 20: Room thermostat HC3, 21: DHW flow switch, 24: Pulse count, 26: Dewpoint monitor, 27: Flow temp setp incr hygro, 30: Swi-on command HP stage 1, 35: Status info suppl source, 36: Charg prio DHW sol fuel boil, 43: Ventilation switch 1, 44: Ventilation switch 2, 45: Ventilation switch 3, 50: Flow measurement Hz, 51: Consumer request VK1 10V, 52: Consumer request VK2 10V, 54: Pressure measurement 10V, 55: Humidity measurement 10V, 56: Room temp 10V, 59: Flow measurement 10V, 60: Temp measurement 10V, 61: Air quality measurement 10V				
5953	S Input value 1 H1			0
5954	S Function value 1 H1			0
5955	S Input value 2 H1			10
5956	S Function value 2 H1			100
5960	S Function input H3 (Connector X86, terminals B2 & M)			None
0: None, 1: Op'mode change zones+DHW, 2: Optg mode changeover DHW, 3: Op'mode changeover zones, 4: Op'mode changeover zone 1, 5: Op'mode changeover zone 2, 6: Op'mode changeover zone 3, 8: Error/alarm message, 9: Consumer request VK1, 10: Consumer request VK2, 11: Release swi pool source heat, 13: Release swi pool solar, 14: Operating level DHW, 15: Operating level HC1, 16: Operating level HC2, 17: Operating level HC3, 18: Room thermostat HC1, 19: Room thermostat HC2, 20: Room thermostat HC3, 21: DHW flow switch, 24: Pulse count, 26: Dewpoint monitor, 27: Flow temp setp incr hygro, 30: Swi-on command HP stage 1, 35: Status info suppl source, 36: Charg prio DHW sol fuel boil, 43: Ventilation switch 1, 44: Ventilation switch 2, 45: Ventilation switch 3, 50: Flow measurement Hz, 51: Consumer request VK1 10V, 52: Consumer request VK2 10V, 54: Pressure measurement 10V, 55: Humidity measurement 10V, 56: Room temp 10V, 59: Flow measurement 10V, 60: Temp measurement 10V, 61: Air quality measurement 10V				
5963	S Input value 1 H3			0
5964	S Function value 1 H3			0
5965	S Input value 2 H3			10
5966	S Function value 2 H3			100
5980	S Function input EX1			<b>Electrical utility lock E6</b>
0: None, 1: Electrical utility lock E6, 2: Low-tariff E5, 4: Overload source E14, 5: Pressure switch source E26, 6: Flow switch source E15, 7: Flow switch consumers E24, 8: Manual defrost E17, 9: Common fault HP E20, 10: Fault soft starter E25, 12: Low-pressure switch E9, 13: High-pressure switch E10, 14: Overload compressor 1 E11, 15: Error/alarm message, 16: Mains supervision E21, 18: Pressure diff defrost E28, 19: Pres sw source int circ E29, 20: Flow sw source int circ E30, 21: Smart grid E61, 22: Smart grid E62, 25: Optg mode change HCs, 26: DHW push.				
5981	S Contact type input EX1	Normally-closed contact (NC) Normally-opened contact (NO)		NO
5982	S Function input EX2			<b>Low-tariff E5</b>
0: None, 1: Electrical utility lock E6, 2: Low-tariff E5, 4: Overload source E14, 5: Pressure switch source E26, 6: Flow switch source E15, 7: Flow switch consumers E24, 8: Manual defrost E17, 9: Common fault HP E20, 10: Fault soft starter E25, 12: Low-pressure switch E9, 13: High-pressure switch E10, 14: Overload compressor 1 E11, 15: Error/alarm message, 16: Mains supervision E21, 18: Pressure diff defrost E28, 19: Pres sw source int circ E29, 20: Flow sw source int circ E30, 21: Smart grid E61, 22: Smart grid E62, 25: Optg mode change HCs, 26: DHW push.				
5983	S Contact type input EX2	Normally-closed contact (NC) Normally-opened contact (NO)		NC
5985	S Contact type input EX3	Normally-closed contact (NC) Normally-opened contact (NO)		NO
6098	S Readjustm collector sensor	-20... 20		0
6100	S Readjustm outdoor sensor	-3... 3 °C	0,1 °C	0 °C
6117	S Central setp compensation	1... 100°C		5 °C
6120	S Frost protection plant	On, Off		On

<b>Line</b>	<b>Function</b>	<b>Setting range or display</b>	<b>Setting increment</b>	<b>Basic setting</b>
6201	<b>S</b> Reset sensors	No, Yes		<b>No</b>
6205	<b>S</b> Reset to default parameters	No, Yes		<b>No</b>
6220	<b>S</b> Software version (RVS)	0... 99		--
6300	<b>S</b> Info 1 OEM	0... 65535		--
6301	<b>S</b> Info 2 OEM	0... 65535		--
<b>LPB system</b>				
6600	<b>S</b> Device address	0... 16		<b>1</b>
<b>Error</b>				
6711	<b>U</b> Reset HP	No, Yes		<b>No</b>
6800	<b>S</b> History 1	Time, Date, Error code		
6802	<b>S</b> History 2	Time, Date, Error code		
6804	<b>S</b> History 3	Time, Date, Error code		
6806	<b>S</b> History 4	Time, Date, Error code		
6808	<b>S</b> History 5	Time, Date, Error code		
6810	<b>S</b> History 6	Time, Date, Error code		
6812	<b>S</b> History 7	Time, Date, Error code		
6814	<b>S</b> History 8	Time, Date, Error code		
6816	<b>S</b> History 9	Time, Date, Error code		
6818	<b>S</b> History 10	Time, Date, Error code		
<b>Maintenance / special regime</b>				
7070	<b>S</b> HP interval	--, 1... 240	1 month	--
7071	<b>S</b> HP time since maint Reset ? (no, yes)	0... 240	1 month	<b>0</b>
7073	<b>S</b> Cur starts compr1/hrs run (since the 6 last weeks) Reset ? (no, yes)	0... 12		<b>0</b>
7141	<b>U</b> Emergency operation	Off, On		<b>Off</b>
	Off: Heat pump functions normally (with boosters if necessary). On: Heat pump uses the electric boost system or the boiler connection. Use the "On" position only in Assist mode or Test mode: may result in high power bills.			
7142	<b>S</b> Emergency operating function type	Manual, Automatic		<b>Manual</b>
	Manual: Emergency mode is not active when a fault occurs (Emergency mode = OFF). Automatic: Emergency mode is active when a fault occurs (Emergency mode = ON). In "Automatic" position, the energy cost can be onerous if the error is not detected and eliminated.			
7150	<b>I</b> Simulation outdoor temp	-50... 50 °C	0,5	--

Line	Function	Setting range or display	Setting increment	Basic setting
<b>Inputs / outputs test</b>				
7700	I Relay test			<b>No test</b>
<p>This consists of instructing the regulator's relays one by one and checking their outputs. This enables you to check that the relays are working and that the cabling is correct. Check that each appliance in the installation is operating correctly.</p> <p>(0) No test, (1) Everything is on STOP, (2) Relay output QX1 : heat pump CC1 (if 1 circuit ) or heat pump CC2 (if 2 circuits), (3) Relay output QX2 : Electrical back-up (1st stage) or Boiler connection distribution valve, (4) Relay output QX3 : Electrical back-up (2nd stage) or Boiler connection contact, (5) Relay output QX4 : DHW distribution valve, (6) Relay output QX5 : DHW Electrical back-up, (7) Relay output QX6 , (8) Relay output QX31 : Heat circ mix valve open Y1 (or control pilot-wire), (9) Relay output QX32 : Heat circ mix valve close Y2, (10) Relay output QX33 : heat pump CC1 if 2 circuits (mixed circuit, the less hot), (11) Relay output QX34, (12) Relay output QX35 : Swimming pool distribution valve, (13) Relay output QX21 module 1, (14) Relay output QX22 module 1, (15) Relay output QX23 module 1, (16) Relay output QX21 module 2, (17) Relay output QX22 module 2, (18) Relay output QX23 module 2, (19) Not used, (20) Not used, (21) Not used.</p> <p>The display shows the "Key" symbol. Pressing the Info button displays "Error 368".</p> <p><b>Warning: The component being tested is receiving electrical power throughout the test.</b></p>				
7710	I Output UX1 test	0... 100%	1	--
7716	I Output UX2 test	0... 100%	1	--
7722	I Digital output DO2	Off, On		<b>Off</b>
7723	I Heat pump D3	Off, On		<b>Off</b>
7724	I Outputs test UX3 ("Inverter" command)	0... 100 %		--
7725	I Voltage value (Ux3)	0... 10 v		--
7804	I Sensor temperature BX1 (HP flow temperature)	-28... 350 °C		--
7805	I Sensor temperature BX2 (HP return temperature)	-28... 350 °C		--
7806	I Sensor temperature BX3 (DHW temperature)	-28... 350 °C		--
7807	I Sensor temperature BX4 (Outdoor temperature)	-28... 350 °C		--
7858	I Input signal H3	None, Closed (ooo), Open (---), Pulse, Frequency Hz, Voltage V		<b>None</b>
7911	I Input EX1 (Power shedding, EJP)	0, 230 V		--
7912	I Input EX2 (Tariffs day/night)	0, 230 V		--
7913	I Input EX3 (External fault)	0, 230 V		--
<b>State</b>				
8000	I State heating circuit 1			--
8001	I State heating circuit 2			--
8003	I State DHW			--
8004	I State cooling circuit 1			--
8006	I State heat pump			--
8007	I State solar			--
8010	I State buffer			--
8011	I State swimming pool			--
8022	I State supplementary source			--
8025	I State cooling circuit 2			--

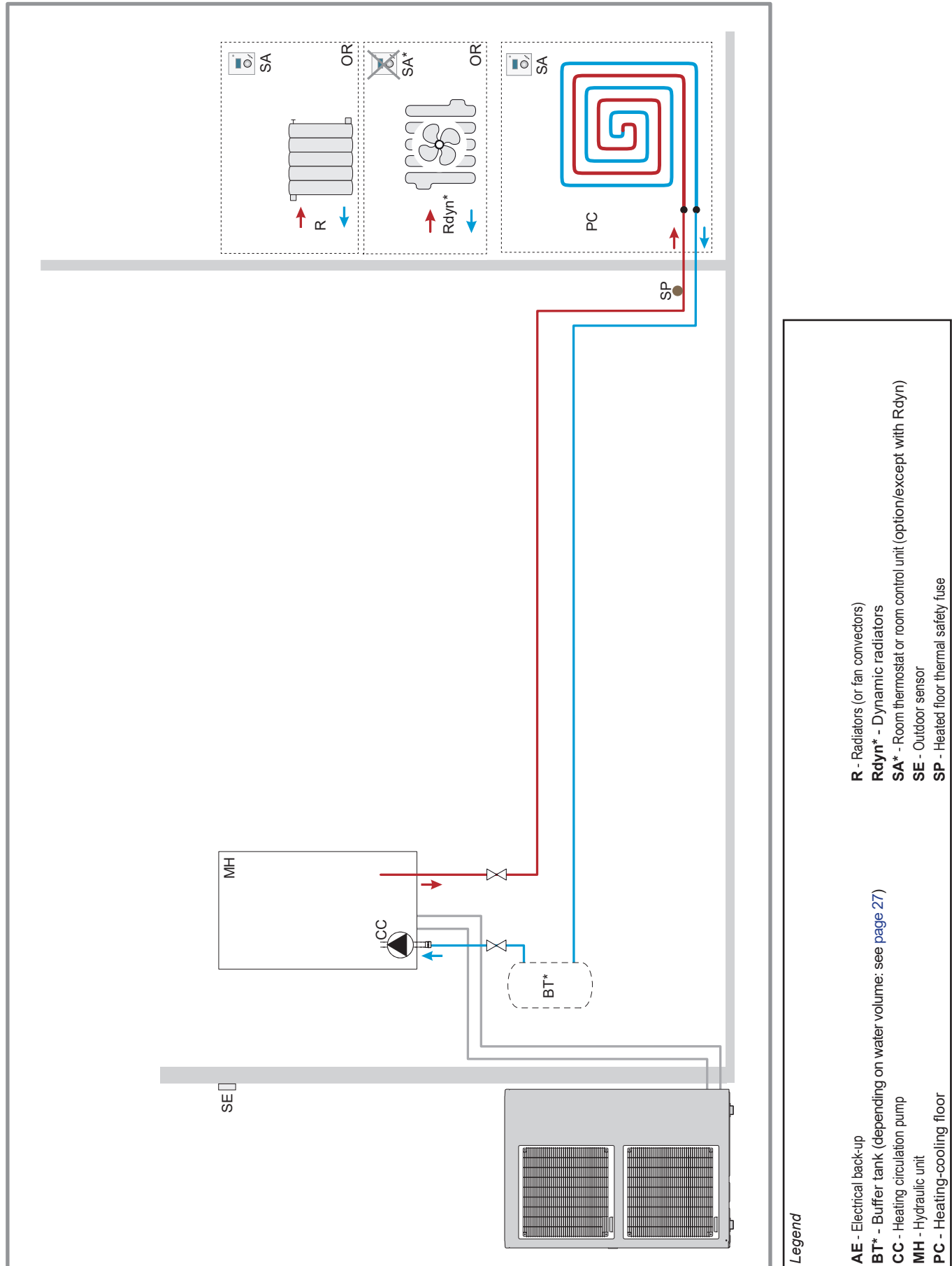


<b>Line</b>	<b>Function</b>	<b>Setting range or display</b>	<b>Setting increment</b>	<b>Basic setting</b>
<b>Generator diagnosis</b>				
8400	I Compressor 1	Off, On		<b>Off</b>
8402	I Electrical resistance flow 1	Off, On		<b>Off</b>
8403	I Electrical resistance flow 2	Off, On		<b>Off</b>
8406	I Condenser pump	Off, On		<b>Off</b>
8407	S Speed condenser pump	0...100%		--
8410	U Return temp HP	0... 140 °C		--
	Setpoint (flow) HP			--
8412	U Flow temp HP	0... 140 °C		--
	Setpoint (flow) HP			--
8413	U Compressor modulation	0... 100%		--
8414	I Modulation electric flow	0... 100%		--
8425	S Temp diff condensor	-50... 140 °C		--
8450	S Hours run compressor 1	00:00		--
8454	S Locking time Heat Pump Reset ? (no, yes)	0... 2730 h		--
8455	S Counter number of locks HP Reset ? (no, yes)	0... 65535		--
8456	S Hours run electrical flow Reset ? (no, yes)	0... 2730 h		--
8457	S Start counter electrical flow Reset ? (no, yes)	0... 65535		--
8458	I State smart grid	Draw disabled, Draw free, Draw wish, Draw forced		<b>Draw free</b>
8460	I Heat pump throughput	0... 65535 l/min		--
<b>Diagnostics consumers</b>				
8700	U Outdoor temperature	-50... 50 °C		--
8701	U Outdoor temp min Reset ? (no, yes)	-50... 50 °C		<b>50 °C</b>
8702	U Outdoor temp max Reset ? (no, yes)	-50... 50 °C		<b>-50 °C</b>
8703	I Outdoor temp attenuated Reset ? (no, yes)	-50... 50 °C		--
	This is the average of the outdoor temperature over a 24-hour period. This value is used for automatic Summer / Winter switchover (line 730).			
8704	I Outdoor temp composite	-50... 50 °C		--
	The mixed outdoor temperature is a combination of the current outdoor temperature and the average outdoor temperature calculated by the regulator. This value is used for calculating the initial temperature.			
8730	I Heating circuit pump, circuit 1	Off, On		<b>Off</b>
8731	I Mixer valve HC1 open	Off, On		<b>Off</b>
8732	I Mixer valve HC1 closed	Off, On		<b>Off</b>
8740	U Room temperature 1	0... 50 °C		--
	Room setting 1			<b>20 °C</b>
8743	U Flow temperature 1	0... 140 °C		--
	Flow temperature setpoint 1			--
8749	I Room thermostat 1	No demand, Demand		<b>No demand</b>

<i>Line</i>	<i>Function</i>	<i>Setting range or display</i>	<i>Setting increment</i>	<i>Basic setting</i>
8756	<b>U</b> Cooling flow temperature 1	0... 140 °C		--
	Cooling flow temperature setpoint 1			--
8820	<b>I</b> DHW pump	Off, On		<b>Off</b>
8821	<b>I</b> EI imm heater DHW	Off, On		<b>Off</b>
8830	<b>U</b> DHW (domestic hot water) temperature	0... 140 °C		--
	DHW temperature setpoint			<b>50 °C</b>
8832	<b>I</b> DHW temp 2	0... 140 °C		--
8840	<b>S</b> Hours run DHW pump	0... 2730 h		--
8841	<b>S</b> Start counter DHW pump	0... 199999		--
8842	<b>S</b> Hours run electric DHW	0... 2730 h		--
8843	<b>S</b> Start counter electric DHW	0... 65535		--
8950	<b>I</b> Common flow temperature	0... 140 °C		--
	Common flow temperature setpoint			--
8957	<b>I</b> Common flow setpoint, refrigeration	0... 140 °C		--
9005	<b>I</b> Water pressure 1	-100... 500 bar		--
9006	<b>I</b> Water pressure 2	-100... 500 bar		--
9009	<b>I</b> Water pressure 3	-100... 500 bar		--
9010	<b>I</b> Measurement room temp 1	0...50 °C		--
9011	<b>I</b> Measurement room temp 2	0... 50 °C		--
9031	<b>I</b> Relay output QX1	Off, On		<b>On</b>
9032	<b>I</b> Relay output QX2	Off, On		<b>On</b>
9033	<b>I</b> Relay output QX3	Off, On		<b>On</b>
9034	<b>I</b> Relay output QX4	Off, On		<b>Off</b>
9035	<b>I</b> Relay output QX5	Off, On		<b>Off</b>

# 8 Overall hydraulic layout

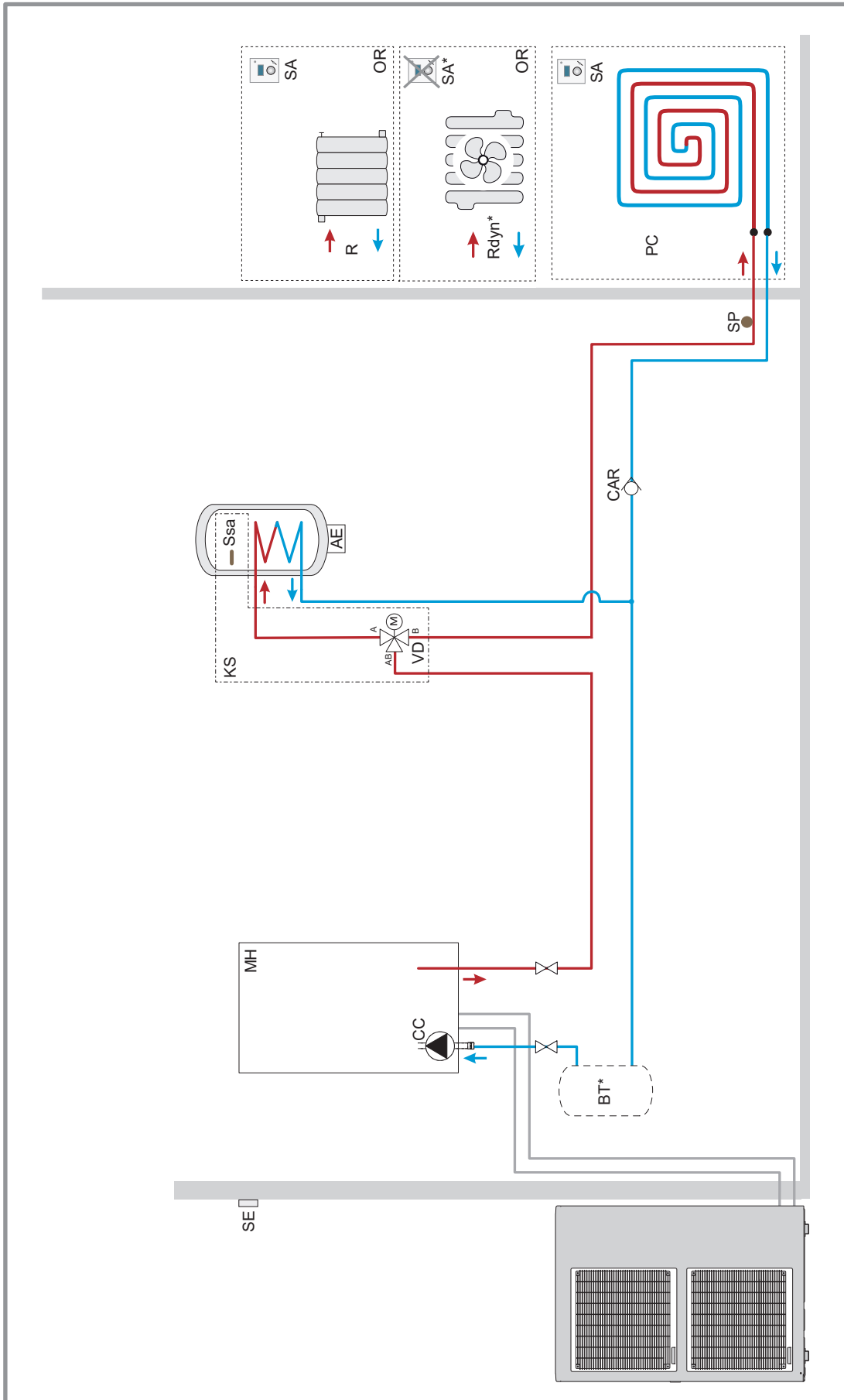
• Configuration 1: 1 heating circuit



**Legend**

- AE** - Electrical back-up
- BT\*** - Buffer tank (depending on water volume: see page 27)
- CC** - Heating circulation pump
- MH** - Hydraulic unit
- PC** - Heating-cooling floor
- R** - Radiators (or fan convectors)
- Rdyn\*** - Dynamic radiators
- SA\*** - Room thermostat or room control unit (option/except with Rdyn)
- SE** - Outdoor sensor
- SP** - Heated floor thermal safety fuse

• Configuration 1: 1 heating circuit and DHW tank (with electrical back-up)



- Legend**
- AE - Electrical back-up
  - BT\* - Buffer tank (depending on water volume: see page 27)
  - CC - Non-return valve
  - CC - Heating circulation pump
  - KS - DHW kit
  - MH - Hydraulic unit
  - PC - Heating-cooling floor
  - R - Radiators (or fan convectors)
  - Rdyn\* - Dynamic radiators
  - SA\* - Room thermostat or room control unit (option/except with Rdyn)
  - SE - Outdoor sensor
  - SP - Heated floor thermal safety fuse
  - Ssa - DHW sensor
  - VD - Distribution valve

# 9 Electrical wiring diagrams

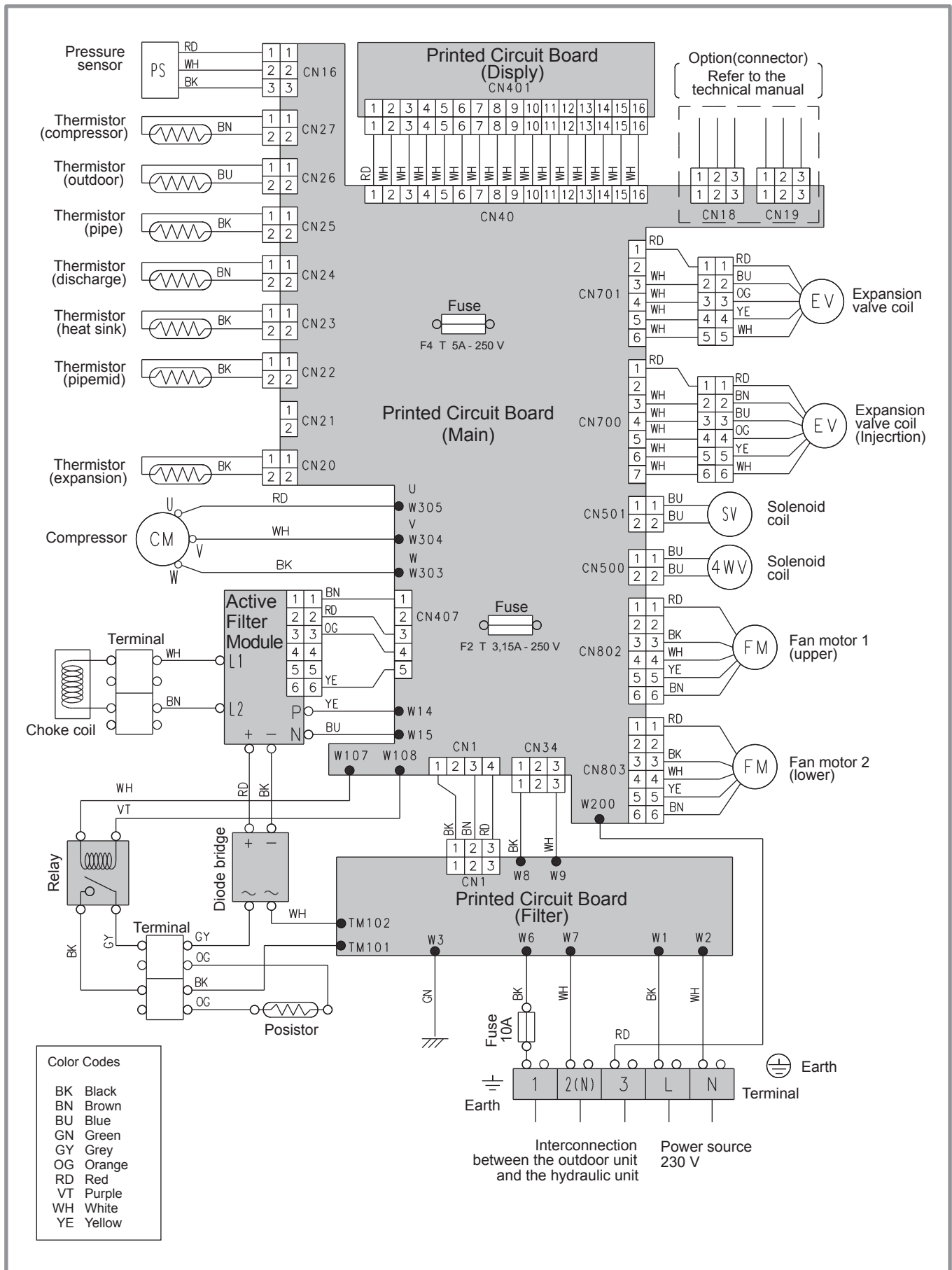


figure 45 - Electrical wiring of outdoor unit Single phase type Waterstage

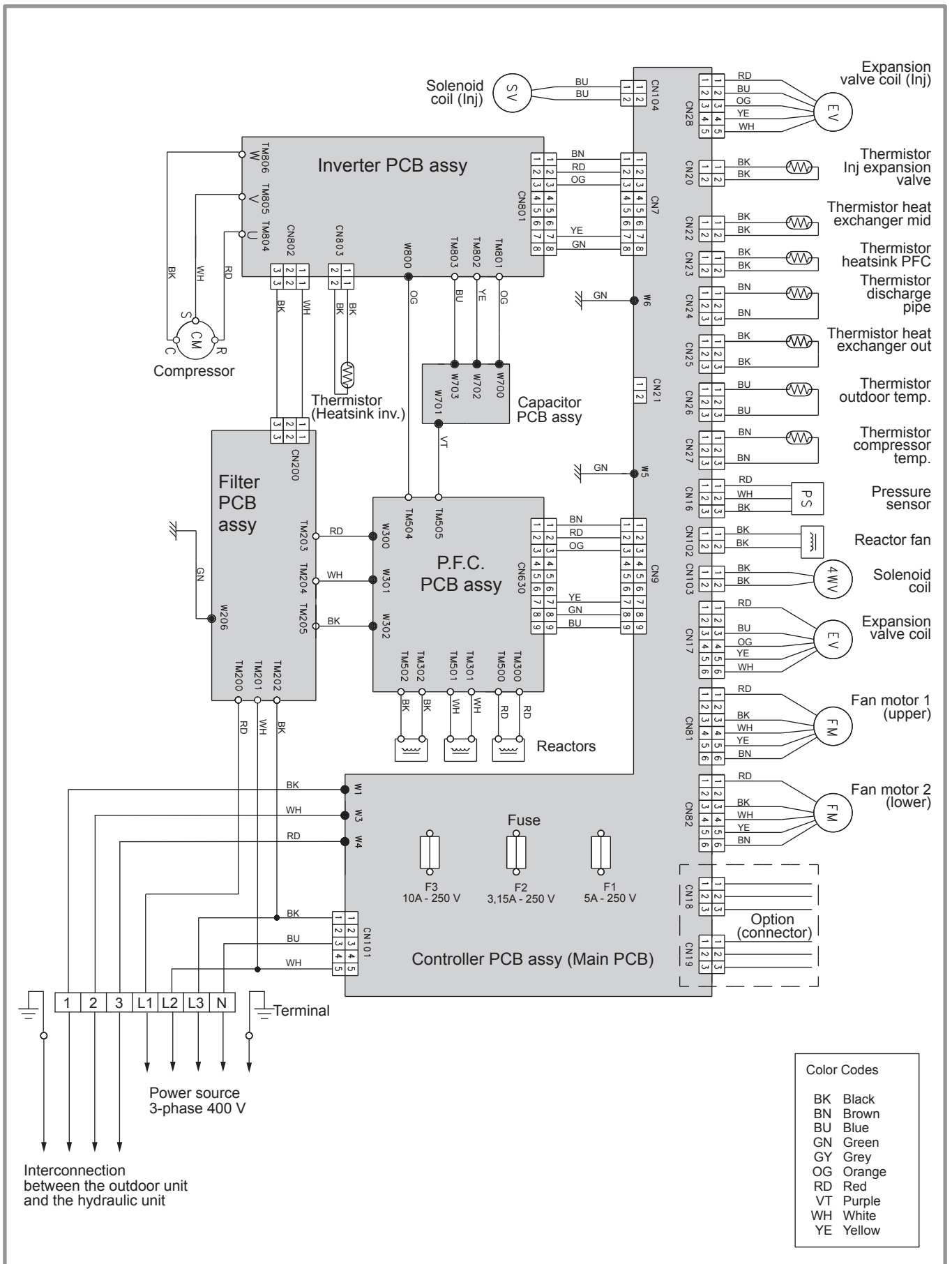


figure 46 - Electrical wiring of outdoor unit 3-phase type Waterstage

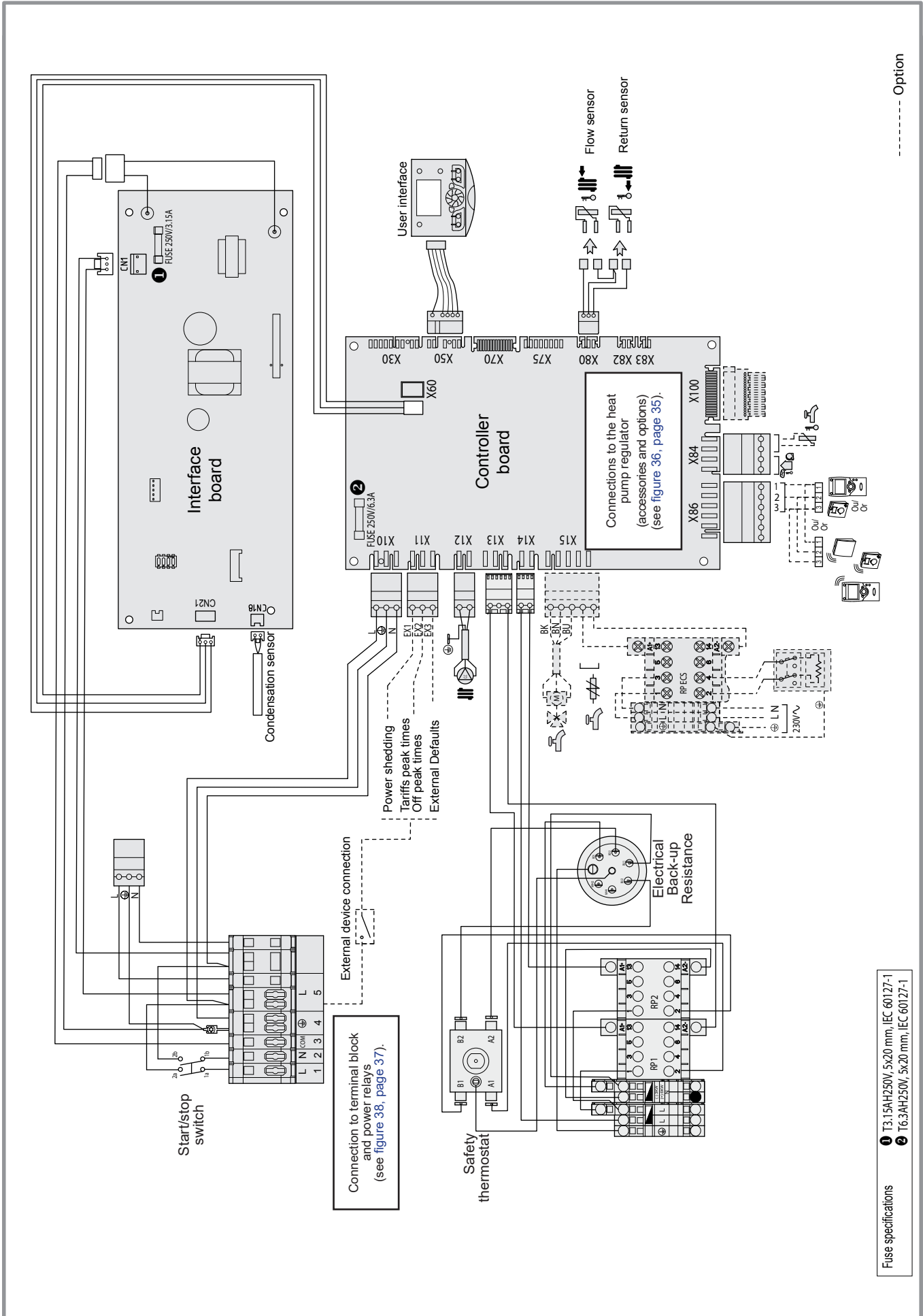


figure 47 - Electrical wiring, Hydraulic unit Single phase type Waterstage



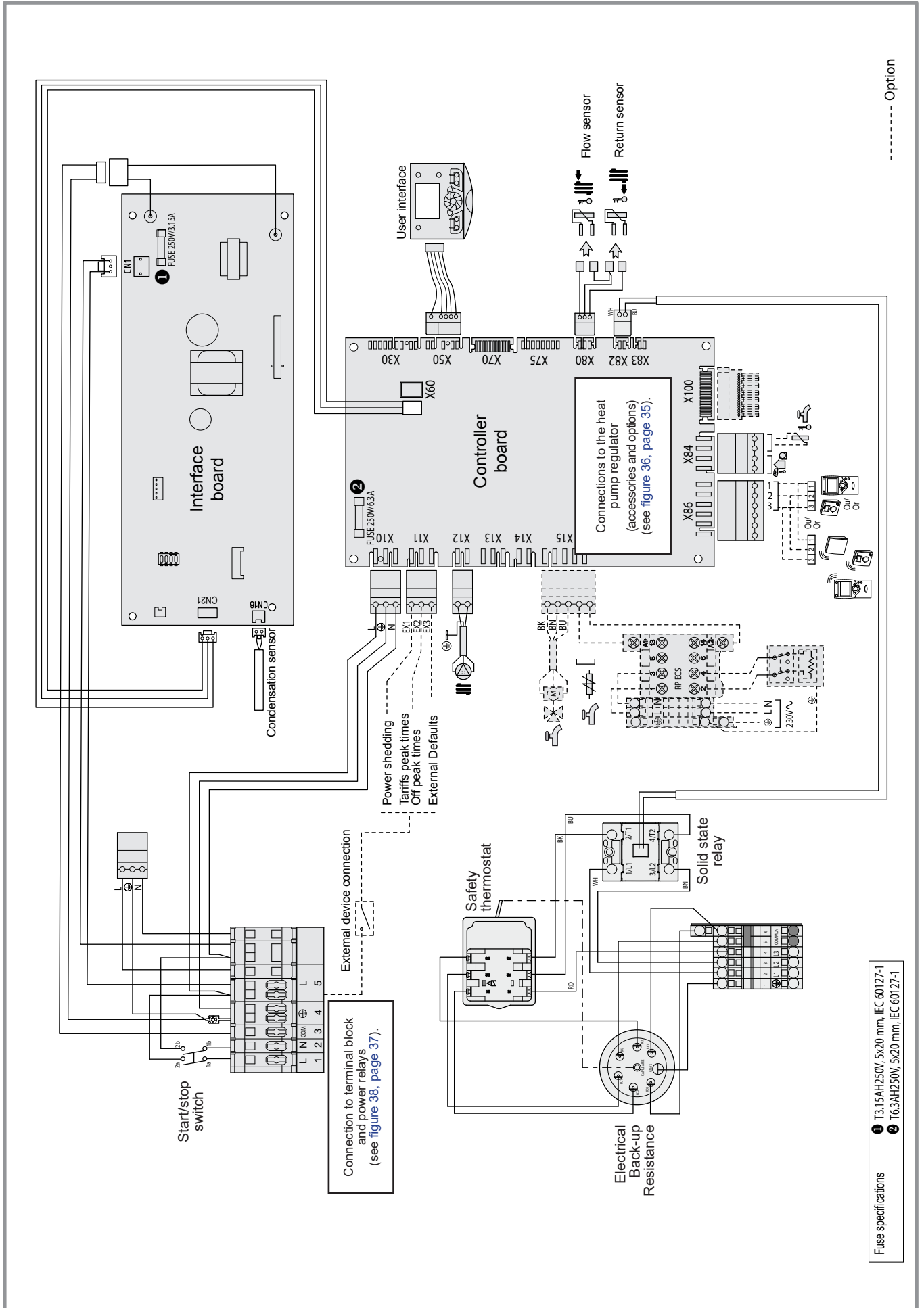


figure 48 - Electrical wiring, Hydraulic unit HP 3-phase (Except installer's connections)

# 10 Troubleshooting

Depending on whether the fault comes from the outdoor unit or the hydraulic unit, the fault may be indicated by the digital display or the LED on the interface cards.

## 10.1 Faults displayed on the hydraulic unit

Faults or breakdowns on the hydraulic unit are indicated by the display on the user interface.

The display shows the  symbol.

Press the  key for more details on the origin of the fault.

When the error has been resolved, the faults are re-initialised at zero automatically.

**Hydraulic unit:** Fault visible on the digital display.

<i>Error number</i>	<i>Error description</i>	<i>Error location</i>	<i>Heat pump operation despite the error</i>
-	No connection.	Failure to comply with room thermostat's polarity.	No
10	Outdoor sensor.	B9	Yes with OT = 0°C
33	Heat pump initial temperature sensor error.	B21	Yes
44	Heat pump return temperature sensor error.	B71	Yes
50	DHW temperature sensor.	B3	Yes
60	Ambient temperature sensor 1.		Yes
65	Ambient temperature sensor 2.		Yes
105	Maintenance message.		Yes
121	Flow temperature for (HC1) not reached.		Yes
122	Flow temperature for (HC2) not reached.		Yes
127	Anti-legionella temperature not reached.		Yes
369	External fault (safety component).		No
370	Outdoor unit connection error. (In the start phase, see the para. "Start-up").	See below.	No
441	2e zone sensor not configured (if 2nd circuits kit)	BX31; Set the parameter 5700 to 2, 4 or 6	No
516	Heat pump missing	Check the wiring between X60 and the interface board.	No

- ☞ Ensure that the general electrical power supply has been cut off before starting any repair work.
- ☞ When the HP is not under tension, protection frost-free is not assured.

**Hydraulic unit:** Flashing of the diode visible on the interface board.

Outdoor unit Error number	LED display		Error contents
	LED 2 (green)	LED 1 (red)	
11	1 Flash	1 Flash	Communication error between Hydraulic unit and Outdoor unit.
23	2 Flashes	3 Flashes	Connection forbidden (series error).
31	3 Flashes	1 Flash	Indoor unit power supply abnormal.
32	3 Flashes	2 Flashes	Serial communication error between Controller /Interface PCBs.
41	4 Flashes	1 Flash	Heat pump capacity signal error (Open or short).
42	4 Flashes	2 Flashes	Hydraulic unit heat-exchange thermistor Error.
61	6 Flashes	1 Flash	Outdoor unit power supply abnormal.
62	6 Flashes	2 Flashes	Outdoor unit main PCB error.
63	6 Flashes	3 Flashes	Inverter error.
64	6 Flashes	4 Flashes	Active filter error.
65	6 Flashes	5 Flashes	Outdoor unit IPM error.
67	6 Flashes	7 Flashes	Outdoor unit power short interruption error (protective operation).
68	6 Flashes	8 Flashes	Outdoor unit magnetic relay error.
71	7 Flashes	1 Flash	Discharge thermistor error.
72	7 Flashes	2 Flashes	Compressor thermistor error.
73	7 Flashes	3 Flashes	Heat-exchange thermistor (outlet / intermediate) error.
74	7 Flashes	4 Flashes	Outdoor thermistor error.
77	7 Flashes	7 Flashes	Outdoor unit heat sink temp. thermistor error.
78	7 Flashes	8 Flashes	Expansion valve thermistor error.
84	8 Flashes	4 Flashes	Current sensor error.
86	8 Flashes	6 Flashes	Pressure sensor error / Pressure switch error.
94	9 Flashes	4 Flashes	Current trip.
95	9 Flashes	5 Flashes	Detection of compressor position error / Compressor start up error.
97	9 Flashes	7 Flashes	Outdoor unit fan1 motor error.
98	9 Flashes	8 Flashes	Outdoor unit fan2 motor error.
A1	10 Flashes	1 Flash	Discharge temperature protection.
A3	10 Flashes	3 Flashes	Compressor temperature protection.
A4	10 Flashes	4 Flashes	Outdoor unit pressure error.
A5	10 Flashes	5 Flashes	Low pressure abnormal.
A9	10 Flashes	9 Flashes	Current overload error.
-	Continuous flashing (1 sec On / 1 sec Off)		Pump down operation.
-	Continuous lighting	Off	Defrosting.

## 10.2 Faults displayed on the single phase outdoor unit

To access the electronic board, you must remove the front (right-hand) facing from the outdoor unit.

Faults are coded by LED flashes.

When an error occurs:

- The LED "**ERROR**" (2) blinks.
- Press once on the switch "**ENTER**" (SW3).
- The "**ERROR**" (2) LED blinks several times depending on the error's type (see below).

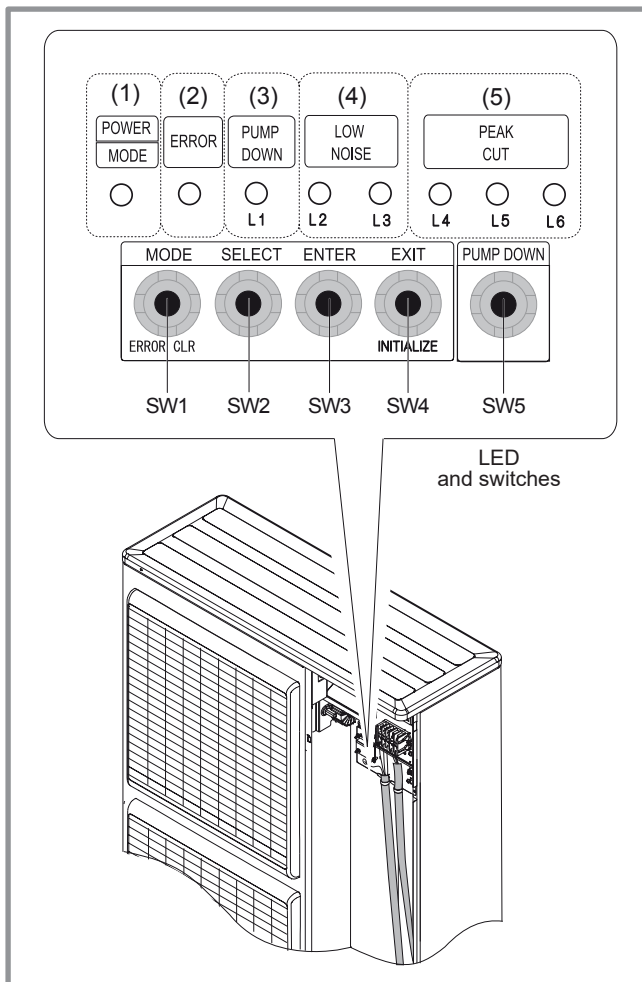


figure 49 - Location of switches and LED on single phase outdoor unit

LED display	Error contents
1 Flash	Serial forward transfer error.
2 Flashes	Discharge thermistor error.
3 Flashes	Pressure sensor error.
4 Flashes	Heat-exchange thermistor (outlet) error.
5 Flashes	Heat-exchange thermistor (intermediate) error.
6 Flashes	Expansion valve thermistor error.
7 Flashes	Outdoor temperature thermistor error.
8 Flashes	Compressor thermistor error.
9 Flashes	Heat sink thermistor error.
11 Flashes	Discharge temperature protection (permanent stoppage).
12 Flashes	Compressor temperature protection (permanent stoppage).
13 Flashes	Current trip (permanent stoppage).
14 Flashes	Detection of compressor position error (permanent stoppage).
15 Flashes	Compressor start up error (permanent stoppage).
16 Flashes	Fan motor 1 error (permanent stoppage).
17 Flashes	Fan motor 2 error (permanent stoppage).
18 Flashes	Inverter error.
19 Flashes	Active filter error.
20 Flashes	Low pressure abnormal.
22 Flashes	Hydraulic unit abnormality condition.

- ☞ Ensure that the general electrical power supply has been cut off before starting any repair work.
- ☞ When the HP is not under tension, protection frost-free is not assured.

### 10.3 Faults displayed on the 3-phase outdoor unit

To access the electronic board, you must remove the front (right-hand) facing from the outdoor unit.

Faults are coded by LED flashes.

When an error occurs:

- The LED "**ERROR**" (2) blinks.
- Press once on the switch "**ENTER**" (SW4).
- The "**ERROR**" (2) LED blinks several times depending on the error's type (see below).

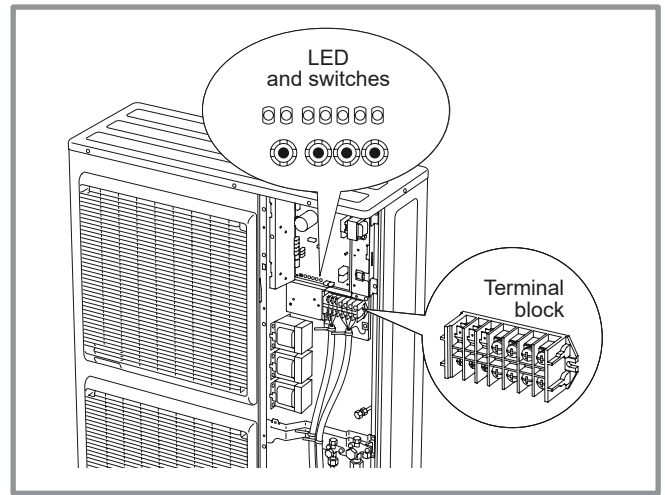


figure 50 - Location of switches and LED on 3-phase outdoor unit

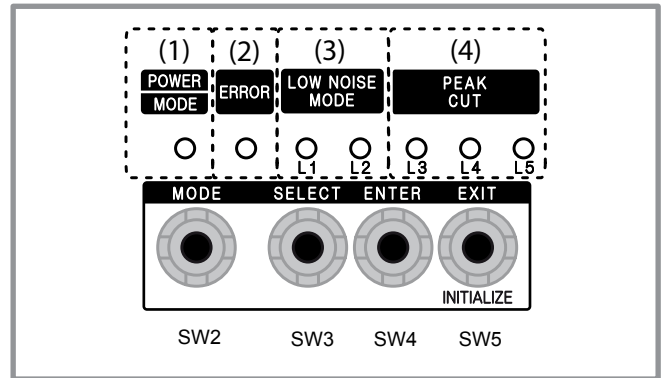



figure 51 - LED display on the 3-phase outdoor unit

LED display	Error contents
1 Flash	Serial forward transfer error.
2 Flashes	Discharge thermistor error.
3 Flashes	Pressure sensor error.
4 Flashes	Heat-exchange thermistor (outlet) error.
5 Flashes	Heat-exchange thermistor (intermediate) error.
6 Flashes	Expansion valve thermistor error.
7 Flashes	Outdoor temperature thermistor error.
8 Flashes	Compressor thermistor error.
9 Flashes	Heat sink thermistor (Inverter) error.
10 Flashes	Heat sink thermistor (P.F.C.) error.
11 Flashes	Discharge temperature protection (permanent stoppage).
12 Flashes	Compressor temperature protection (permanent stoppage).
13 Flashes	Current trip (permanent stoppage).
14 Flashes	Detection of compressor position error (permanent stoppage).
15 Flashes	Compressor start up error (permanent stoppage).
16 Flashes	Fan motor 1 error (permanent stoppage).
17 Flashes	Fan motor 2 error (permanent stoppage).
18 Flashes	Inverter error.
19 Flashes	P.F.C. error.
20 Flashes	Low pressure abnormal.
22 Flashes	Hydraulic unit abnormality condition.

## 10.4 Information display

Various data can be displayed by pressing the  button.

Depending on the type of unit, configuration and operating state, some of the info lines listed below may not appear.

- Possible error messages from the error code list (see table, [page 66](#)).
- Possible service messages from the maintenance code list.
- Possible special mode messages.

- Various data (see below).

<b>Designation</b>	<b>Line</b>
Floor drying current setpoint .	-
Current drying day.	-
Terminated drying days.	-
State heat pump.	8006
State supplementary source.	8022
State DHW.	8003
State swimming pool.	8011
State heating circuit 1.	8000
State heating circuit 2.	8001
State cooling circuit 1.	8004
Outdoor temperature.	8700
Room temperature 1.	8740
Room setpoint 1.	
Flow temperature 1.	8743
Flow temperature setpoint1.	
Room temperature 2.	8770
Room setpoint 2.	
Flow temperature 2.	8773
Flow temperature setpoint 2.	
DHW (domestic hot water) temperature.	8830
Heat pump return temperature.	8410
Setpoint (return) HP.	
Heat pump flow temperature.	8412
Setpoint (flow) HP.	
Swimming pool temperature.	8900
Swimming pool temperature setpoint.	
Minimum remaining stop time for compressor 1.	-
Minimum remaining running time for compressor 1.	-

# 11 Maintenance of the installation

Ensure that the general electrical power supply has been cut off before starting any repair work.

## 11.1 Hydraulic checks

- ☞ **Warning : If frequent refills are required it is essential that you look for any leaks. If filling and re-pressurization are required, check what type of fluid has been used initially.**

Recommended filling pressure: 1 to 2 bar (Precise filling pressure is determined by the manometric height of the installation).

Each year,

- Check the expansion vessel pressure (precharge 1 bar) and the correct functioning of the safety valve.

If the installation is fitted with a DHW tank:

- Verify the safety unit on the cold water supply inlet. Make it work as prescribed by the manufacturer.
- Check the shut-off.

## 11.2 Checking the outdoor unit

- Dust off the heat exchanger if necessary, being careful not to damage the fins.
- Straighten the vanes using a comb.
- Check that there is nothing obstructing the passage of air.
- Check the fan.
- Verify that condensate drain is not obstructed.

### • Checking the refrigeration circuit

When the refrigerant charge is in excess of 2kg (models >10kW) it is compulsory to have an approved after sales service check the refrigeration circuit every year (with a certificate of capacity for the handling of refrigerants).

- Check the lack of leak (connections, valves...).

## 11.3 Electrical checks

- Check connections and possible tightening.
- Check the cables condition and electronic boards.

# 12 Maintenance

## 12.1 Emptying the hydraulic unit

- Remove the front panel from the hydraulic unit.
- Open the emptying valve,
- Open the hydraulic unit's manual bleed-tap,
- Open the installation bleed tap.

## 12.2 Distribution valve

If the installation is fitted with a DHW tank.

Carefully comply with the direction for fitting the distribution valve.

Channel **AB** : Inlet to the hydraulic unit .

Open channel **A** : Return from DHW tank.

Open channel **B** : Return from the heating circuit.

# 13 Quick-start procedure

Before switching on the hydraulic unit:

- Check the electric wiring.
- Check the refrigeration circuit and make sure the gas supply has been performed.
- Check the pressure of the hydraulic circuit (1-2 bar), check that the heat pump is purged, and the rest of the installation.
- Make sure that ALL DIP SW are OFF before starting up.

## 13.1 Start-up check-list

### 13.1.1 Before starting-up

#### • Sight checks

Outdoor unit (see chapter "Installation of the outdoor unit", page 14).	OK	Non compliant	
Location and fittings, condensate evacuation.			
Compliance with distances from obstacles.			

#### • Hydraulic checks

Hydraulic unit (see chapter "Installing the hydraulic unit", page 16).	OK	Non compliant	Value
Connection of pipes, valves and pumps (1 or 2 circuits, DHW).			
Installation water volume (expansion vessel of adequate capacity ?).			
No leaks.			
Main system pressure and degassing.			

#### • Refrigeration connections and checks

(see chapters "Refrigerant gas connection and filling the installation with gas", page 17 & "Filling the installation with gas", page 22).	OK	Non compliant	
Refrigerant circuits control (Sealing respected, no dust and moisture).			
Connections between units (pipe length, flare tightening torque...).			
Installation of HP, LP pressure switches on "Gas" line (large pipe).			
Pump down required.			
Nitrogen leak test (~ 10 bar).			
Opening of refrigeration valves to outdoor unit.			
Refrigerant filling of hydraulic unit and pipes.			

#### • Electrical checks

Outdoor unit (see chapter "Electrical connections", page 30).	OK	Non compliant	Value
Main power supply (230 V or 400 V).			
Protection by rated circuit breaker.			
Cable cross-section.			
Earth connection.			

Hydraulic unit (see chapter "Electrical connections on the hydraulic unit side", page 34).	OK	Non compliant	
Connection with outdoor unit (phase, neutral, earth or 3 phases + earth).			
Sensors connection (positioning and connections).			
3 way valve and circulators connections.			
Power supply and protection of electric auxiliary			



### 13.1.2 Starting-up

#### • Switching On

(see chapter "Commissioning", page 38 & chapter "List of function lines (settings, diagnosis, status)", page 45).	OK	Non compliant	
Close the installation's main circuit breaker (power supply to the outdoor unit) <u>2 hours before starting up the tests</u> => The compressor to pre-heat.			
Turn ON the start/stop switch => Initialisation for a few seconds.			
Operation of the heating pump.			
Outdoor unit starts after 4 mins.			
Configure Time, Date and time programs for HC1, HC2 if different than default values.			
Configure the hydraulic circuit (setting 5700).			
Ajust the heating curve slope (720 & 1020).			
Adjust the maximum start setting (741 & 1041).			

#### • Outdoor unit checks

	OK	Non compliant	Value
Operation of fan(s), compressor.			
Current measurement.			
After a few minutes, measurement of air temp. delta.			
Check condensation and evaporation pressure/temperature.			

#### • Hydraulic unit checks

	OK	Non compliant	Value
After 15 mins of operation.			
Primary water temp. delta.			
Operation of heating, mixing valve, boiler backup, ...			

#### • Room control

(see chapter "Configuring room thermostat", page 39 & chapter "List of function lines (settings, diagnosis, status)", page 45).	OK	Non compliant	
Settings, manipulations, checks.			
Set the scheduled periods for heating (500 to 516 & 520 to 536).			
Adjust the heating setpoints (710-714 ; 1010-1014), if different than default values.			
Setpoint display.			
Explanations on use.			

**The heat pump is ready for operation !**

## 13.2 Settings sheet

Setting	Description	Set to.	Menus
<b>Preliminary settings</b>			
20	language		<i>operator section</i>
1	hour / minutes		<i>time &amp; date</i>
2	day / month		<i>time &amp; date</i>
3	year		<i>time &amp; date</i>
5700	installation config.		<i>configuration</i>
<b>Heating circuit No. 1 if 2 circuits = the least warm one (e.g.: floor)</b>			
710	comfort setpoint		<i>HC1 adjust.</i>
712	reduced setpoint		<i>HC1 adjust.</i>
720	heating curve slope		<i>HC1 adjust.</i>
741	flow temp setpoint max		<i>HC1 adjust.</i>
750	room influence		<i>HC1 adjust.</i>
790 / 791	optimis. at switch-on / off		<i>HC1 adjust.</i>
834	servomotor travel time		<i>HC1 adjust.</i>
850 / 851	floor drying		<i>HC1 adjust.</i>
<b>Heating circuit No. 2 (with 2<sup>nd</sup> circuit option) = the warmest one (e.g.: radiators)</b>			
1010	comfort setpoint		<i>HC2 adjust.</i>
1012	reduced setpoint		<i>HC2 adjust.</i>
1020	heating curve slope		<i>HC2 adjust.</i>
1041	flow temp setpoint max		<i>HC2 adjust.</i>
1050	room influence		<i>HC2 adjust.</i>
1090 / 1091	optimis. at switch-on / off		<i>HC2 adjust.</i>
1134	servomotor travel time		<i>HC2 adjust.</i>
1150 / 1151	floor drying		<i>HC2 adjust.</i>
<b>Domestic Hot Water (if DHW kit)</b>			
1610	nominal DHW temp. setpoint		<i>DHW</i>
1612	reduced DWH temp. setpoint		<i>DHW</i>
1620	DHW release		<i>DHW</i>
1640 to 1642	legionella cycle		<i>DHW</i>
5024	DHW switch-on differ.		<i>DHW tank</i>
5030	charging time limitation		<i>DHW tank</i>
5061	heater release		<i>DHW tank</i>

Setting	Description	Set to.	Menus
<b>Boiler backup</b>			
3700	OT.switch-on authoris.		<i>addit. gen.</i>
3705	switch-off delay		<i>addit. gen.</i>
<b>Miscellaneous</b>			
6420	input H33 function	1	<i>configuration</i>
6100	OT sensor correction		<i>configuration</i>
6120	frost protection on/off		<i>configuration</i>
6205	reset settings		<i>configuration</i>
6220	software version		<i>configuration</i>
6711	reset heat pump		<i>error</i>
<b>Cooling</b>			
5711	cooling unit	2 pipes	<i>configuration</i>
<b>Faults (if a fault occurs, press "Info" key)</b>			
No. 10	outdoor sensor		
No. 33	flow temp. sensor		
No. 44	return temp. sensor		
No. 50	DHW temp. sensor		
No. 60	room sensor 1		
No. 65	room sensor 2		
No. 105	maintenance message		
No. 121	HC1 flow T not reached		
No. 122	HC2 flow T not reached		
No. 127	leg. prot. T not reached		
No. 369	external fault (EX3)		
No. 370	outdoor unit connect error		
6711	reset heat pump		<i>error</i>
<b>Heat pump</b>			
2844	switch-off temp max		<i>heat pump</i>
2884	OT auth. to start elec. aux.		<i>heat pump</i>
2920	Pk day clear (EX1) rel / lock		<i>heat pump</i>
<b>Swimming pool (with "swimming pool" kit option)</b>			
2056	generator setpoint		<i>Sw pool</i>
<b>Outdoor unit faults (see page 68)</b>			

### 13.3 Start-up data sheet

<b>Site</b>		<b>Installer</b>		
<b>Outdoor unit</b>	Serial No.	<b>Hydraulic unit</b>	Serial No.	
	Model		Model	
<b>Refrigerant type</b>		<b>Refrigerant charge</b> kg		
<b>Checks</b>		<b>Operating voltage &amp; current on outdoor unit</b>		
Compliance with positioning distances		L/N or L1/N	V	
Condensate evacuation correct		L2/N	V	
Electric connections / connections tightnees		L3/N	V	
No GAS leaks (unit ID No. : )		L/T or L1/T	V	
Installation of refrigeration connection correct (lenght : m)		L2/T	V	
<b>Reading in HEATING operating mode</b>		L3/T	V	
Compressor discharge temperature °C		N/T	V	
Liquid line temperature °C		Icomp	A	
Condensation temperature	HP = bar °C	sub-cooling °C		
Tank water output temperature	°C	ΔT condensation °C		
Tank water input temperature	°C	ΔT secondary °C		
Evaporation temperature	LP = bar °C			
Suction temperature	°C	Overheating °C		
Battery air input temperature	°C	ΔT evaporation °C		
Battery air output temperature	°C	ΔT battery °C		
<b>Hydraulic system of hydraulic unit</b>				
Secondary system	Low temp. heating floor	}	Circulator brand	Type
	LT Radiators			
	fan coils			
Domestic hot water ; tank type				
Estimated water volume of secondary system		L		
<b>Options &amp; accessories :</b>				
Power supply for connected electric auxiliary		Room thermostat		
Operation in cooling mode possible		Wireless room thermostat		
Location of room sensor correct		Remote control		
Cooling kit		Wireless remote control		
DHW kit				
2 zone kit		Details		
<b>Control settings</b>				
Configuration type				
Essential settings				

## ErP performance values

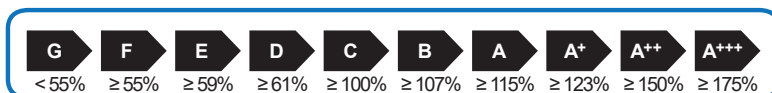
### • ErP Definition

"ErP" includes two directives that are part of the program for the reduction of green house gas emission :

- Eco-design directive sets efficiency thresholds and prohibits the sale of any product with efficiency lower than the set thresholds.
- According to labelling directive, energetic efficiency shall be displayed to encourage end-users to purchase energy-efficient products.

### • Package (High power models)

#### ☞ Application 35°C

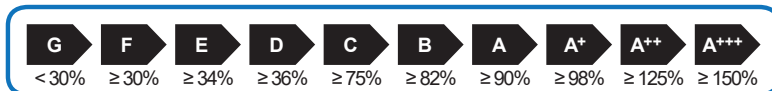


Models	Waterstage ...	HP 11 Single phase		HP 14 Single phase		HP 11 3-Phase		HP 14 3-Phase		HP 16 3-Phase	
<b>Hydraulic unit reference</b>		WSYG140DG6		WSYG140DG6		WSYK160DG9		WSYK160DG9		WSYK160DG9	
Seasonal space heating energy efficiency of heat pump		151%		148%		154%		150%		149%	
Type of temperature control (* = Outdoor sensor ; ** = Room unit )		* classe II	** classe VI	* classe II	** classe VI	* classe II	** classe VI	* classe II	** classe VI	* classe II	** classe VI
Bonus		2%	4%	2%	4%	2%	4%	2%	4%	2%	4%
Seasonal space heating energy efficiency of package <b>under average climate</b>		153%	155%	150%	152%	156%	158%	152%	154%	151%	153%
Energy class of package		A++	A++	A++	A++	A++	A++	A++	A++	A++	A++
Seasonal space heating energy efficiency of package <b>under warmer climate</b>		173%	175%	178%	180%	207%	209%	198%	200%	190%	192%
Seasonal space heating energy efficiency of package <b>under colder climate</b>		123%	125%	120%	122%	126%	128%	124%	126%	121%	123%

The energy efficiency of the package of products provided for in this fiche may not correspond to its actual energy efficiency once installed in a building, as the efficiency is influenced by further factors such as heat loss in the distribution system and the dimensioning of the products in relation to building size and characteristics.

Electrical back up heater consumption is taken into account in the performance calculation.

#### ☞ Application 55°C



Models	Waterstage ...	HP 11 Single phase		HP 14 Single phase		HP 11 3-Phase		HP 14 3-Phase		HP 16 3-Phase	
<b>Hydraulic unit reference</b>		WSYG140DG6		WSYG140DG6		WSYK160DG9		WSYK160DG9		WSYK160DG9	
Seasonal space heating energy efficiency of heat pump		112%		113%		112%		117%		117%	
Type of temperature control (* = Outdoor sensor ; ** = Room unit )		* classe II	** classe VI	* classe II	** classe VI	* classe II	** classe VI	* classe II	** classe VI	* classe II	** classe VI
Bonus		2%	4%	2%	4%	2%	4%	2%	4%	2%	4%
Seasonal space heating energy efficiency of package <b>under average climate</b>		114%	116%	115%	117%	114%	116%	119%	121%	119%	121%
Energy class of package		A+	A+	A+	A+	A+	A+	A+	A+	A+	A+
Seasonal space heating energy efficiency of package <b>under warmer climate</b>		122%	124%	121%	123%	138%	140%	139%	141%	143%	145%
Seasonal space heating energy efficiency of package <b>under colder climate</b>		102%	104%	102%	104%	102%	104%	102%	104%	102%	104%

The energy efficiency of the package of products provided for in this fiche may not correspond to its actual energy efficiency once installed in a building, as the efficiency is influenced by further factors such as heat loss in the distribution system and the dimensioning of the products in relation to building size and characteristics.

Electrical back up heater consumption is taken into account in the performance calculation.

Outdoor sensor included in the package	
Controller class	II
Contribution to energy efficiency	2%

Room unit references	UTW-C55XA UTW-C58XD UTW-C74TXF UTW-C74HXF UTW-C78XD
Controller class	VI
Contribution to energy efficiency	4%

## Instructions for the user

Explain to the user how his installation operates, in particular the functions of the room thermostat and the programmes accessible to him from the user interface.

Emphasise that a heated floor has significant inertia and that therefore any adjustments must be made progressively.

Also explain to the user how to check the filling of the heating circuit.

### ☞ End of life of the device

Disassembly and recycling shall be handled by a qualified body. Wild disposal is strictly prohibited.

At the end-of-life of the equipment, please contact your installer or any local representative to proceed to disassembly and recycling.







Complies with :

- Low voltage directive 2014/35/EC, under standard EN 60335-1, EN 60335-2-40, EN 60529, EN 60529/A2 (IP),
- Electromagnetic compatibility Directive 2014/30/CE,
- Directive 2006/42/EC Machinery,
- Directive for pressurised equipment 2014/68/CE under standard EN 378-2,
- Eco-design directive 2009/125/CE,
- Labelling directive 2010/30/CE.

---

This appliance also conforms to:

- Regulation 842/2006 of the European Parliament on certain fluorinated greenhouse gases.
  - The standards relating to the product and the testing methods used: Air-conditioners, refrigeration units and heat pumps with compressor driven by electric motor for heating and refrigeration EN 14511-1, 14511-2, 14511-3, and 14511-4.
  - To standard EN 12102: Air-conditioners, heat pumps and dehumidifiers with compressor driven by electric motor. Measurement of airborne noise. Determination of acoustic power level.
- 



---

This appliance is marked with this symbol. This means that electrical and electronic products shall not be mixed with general household waste. European Community countries(\*), Norway, Iceland and Liechtenstein should have a dedicated collection system for these products.

Do not try to dismantle the system yourself as this could have harmful effects on your health and on the environment.

The dismantling and treatment of refrigerant, oil and other parts must be done by a qualified installer in accordance with relevant local and national regulations.

This appliance must be treated at a specialized treatment facility for re-use, recycling and other forms of recovery and shall not be disposed of in the municipal waste stream.

Please contact the installer or local authority for more information.

\* subject to the national law of each member state

---

*Date of installation :*

*Contact of your heating technician or your after-sales service.*